

Level Measurement

Continuous level measurement – Guided wave radar transmitters

SITRANS LG200

Overview



SITRANS LG200 is a guided wave radar transmitter for short and medium range level, level/interface, and volume measurement of liquids and solids. It is unaffected by changes in process conditions, high temperatures and pressures, and steam.

Benefits

- Coaxial, rigid, and flexible single or twin rods for many applications
- Measures accurately on materials with dielectric (dK) as low as 1.4 (including LNG at -196 °C (-320.8 °F))
- Guided wave radar measurement for up to 2.5 mm (0.12 inch) accuracy
- Measures level and interface on challenging applications including foam
- 3 button programming for quick setup
- Reliable level measurement on harsh applications with pressure up to 430 bar g (6 250 psi g) and temperatures as high as 427 °C (800 °F).
- Functional Safety (SIL-1 and SIL-2). Device suitable for use in accordance with IEC 61508 and IEC 61511.

Application

SITRANS LG200 provides accurate measurement in level, volume, and interface applications. For short and extended applications, LG200 offers coaxial, single or twin rod probes, and single or twin cable probes up to 22.5 m (75 ft).

SITRANS LG200 measures accurately in liquid or slurry applications of corrosive vapors, foam, saturated steam, high viscosity, quick fill/empty rates, low levels and varying dielectrics and product densities.

Ideal for retrofitting torque tube applications, SITRANS LG200 chamber replacement probe can be mounted in existing chambers or cages for optimal measurement.

- Key Applications: hydrocarbon processing, interface/level measurement, low dielectric liquids, high temperature/pressure applications, powdered solids with high angle of repose.
Applications on ammonia are also possible with the HT/HP coaxial probe design which incorporates a glass seal that is not susceptible to the vapors seen in this application.

Level Measurement

Continuous level measurement – Guided wave radar transmitters

SITRANS LG200

Configuration

Mounting on a nozzle

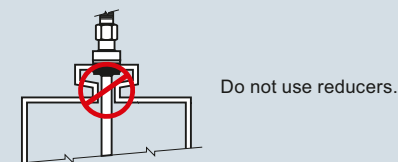
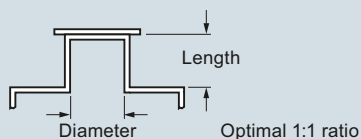

Single rod mounting

1. Do not mount in nozzles <math>< 50 (2)</math> in diameter.
2. Mount in applications where ratio of diameter to length is 1:1 or greater. Any ratio less than 1:1 (i.e. 2" x 6" nozzle = 1:3) may require a blanking distance and/or dielectric adjustment.
3. Do not use pipe reducers.
4. Keep conductive objects away from probe to ensure proper performance.

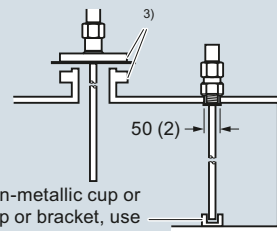

Probe can be stabilized at the bottom with a non-metallic cup or bracket. When mounting into a metallic cup or bracket, use optional TFE bottom spacer (7ML1930-1DJ).

Twin rod mounting 7ML1302-x

1. Active rod must be mounted at least 25 (1) away from any obstructions.
2. Minimum stillwell or nozzle diameter for probe is 76 (3), inactive part needs to be flush with inside tank wall.

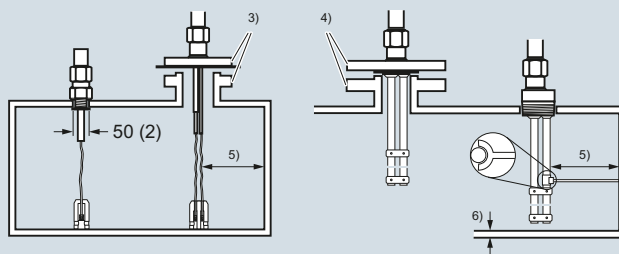

Coaxial 7ML1301-x/coaxial-interface 7ML1301-6

1. Minimum 25 (1) from tank bottom
2. Minimum 2" process connection for enlarged coaxial probe
3. Distance to obstructions not important due to enclosed design

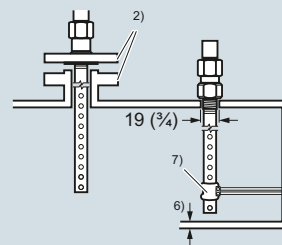

Installation in non-metallic silos ¹⁾

For installation in vessels of a non-metallic construction or possibly open vessels, a suitable launch plate is required to optimize the impedance of the transmitted signal as it travels along the probe. Optimal performance cannot be guaranteed if a suitable transition is not available at the process connection.

When using single rod versions (flexible or solid) and a threaded process connection, a metal sheet or flange will greatly improve conditions as this provides a suitable launch plate.

A flanged process connection is generally accepted to be provision of this launch plate.

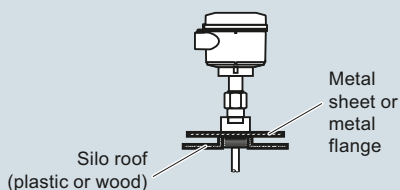

Bypass pipe

1. Minimum pipe diameter 50 (2)
2. Minimum 25 (1) from bottom of the bypass pipe
3. Take note of bottom transition zone for chosen probe, see probe type table
4. For pipe diameters less than 50 (2) consult factory

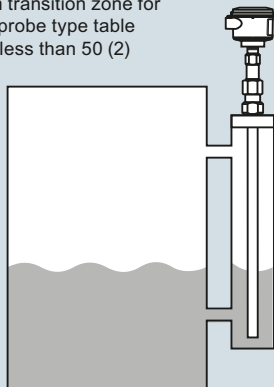

Displacer/torque tube replacement

1. With Coaxial Probe 7ML1301-4 there is no top transition zone allowing measurement to the process connection.
2. Minimum pipe size: coaxial probes 2 inch/DN 50, twin rod 3 inch/DN 80, single rod 2 inch/DN 50
3. 22 (0.875) Coaxial probes should be used where limited build up is expected.

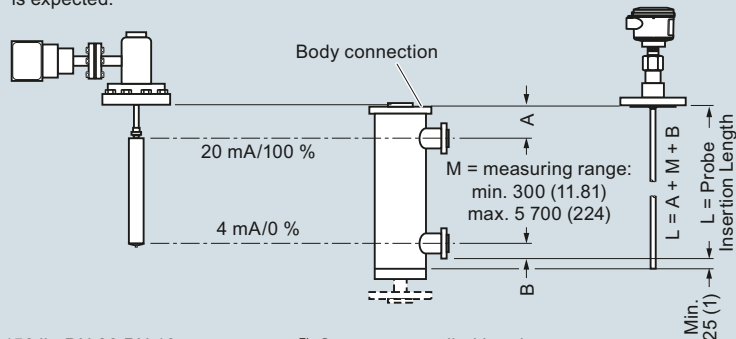

¹⁾ See electromagnetic compatibility
²⁾ Min. 1 inch - 150 lb, DN 25 PN 16
³⁾ Min. 2 inch - 150 lb, DN 25 PN 16

⁴⁾ Min. 3 inch - 150 lb, DN 80 PN 16
⁵⁾ Min. 25 (1) from any metal object
⁶⁾ Min. 25 (1) from tank bottom

⁷⁾ Customer supplied brackets
 Recommended:
 1 bracket per 3 m length

SITRANS LG200 installation, dimensions in mm (inch)

Level Measurement

Continuous level measurement – Guided wave radar transmitters

SITRANS LG200

Technical specifications

Mode of operation		Design	
Measuring principle	Guided wave radar measurement	Weight of transmitter with solid lid	1.28 kg (2.83 lb)
Measuring range	0.15 ... 22.5 m (0.5 ... 75 ft)	Weight of transmitter with glass window lid	1.60 kg (3.52 lb)
Output		Materials	Aluminum, epoxy-coated Type 4/NEMA 4, IP65 2x M20x1.5 or 2 x 1/2" NPT
mA analog output with HART digital signal	Optically isolated 4 ... 20 mA, 620 Ω max.	• Enclosure	
Output range	3.8 ... 20.5 mA usable	• Degree of protection	G 3/4" [(BSPP), EN ISO 228-1], 1", 1 1/2", 2" NPT [(Taper), ANSI/ASME B1.20.1] and G 2" [(BSPP), EN ISO 228-1]
• Analog	4.0 mA	• Cable inlet	
• Start-up current	Adjustable 3.6 mA, 22 mA, HOLD	Process connections	3/4 ... 4", ASME, DIN flanges 3/4 ... 4", Triclover
Diagnostic alarm	HART Version 5.x and multidrop compatible	• Threaded	
Digital communication	Reference Conditions 1.82m (72 inch) Coaxial Probe with water at 20 °C (70 °F) and CFD Threshold	• Flanged	3/4 ... 4", ASME, DIN flanges 3/4 ... 4", Triclover
		• Hygienic	
Performance		Programming	
Non-linearity	< 0.1% of probe length or 2.5 mm (0.1 inch), whichever is greater	Local	Three button, menu-driven data entry with security passwords
• Coaxial/twin rod probes	< 0.1% of probe length or 2.5 mm (0.1 inch), whichever is greater [(top 60 cm (24 inch) of twin rod probes 30 mm (1.2 inch))]	Remote	SIMATIC PDM via HART
• Single rod probes	< 0.3 % or 0.3 inch (8 mm), whichever is greater	Power	
• Interface models	Upper layer: ± 25.4 mm (1 inch) Interface layer: ± 25.4 mm (1 inch) (distinct interface surface required)		11 ... 36 V DC
Resolution and repeatability	≤ 2.5 mm (0.1 inch)	Certificates and approvals	
Accuracy	< 0.1 % of probe length or 0.1 inch (2.5 mm), whichever is greater [Top 60 cm (24 inch) of twin rod probes 30 mm (1.2 inch)]	General Purpose	CSA/FM, CE, C-TICK FM Class I, Div. 1, Groups A, B, C, D, Class II, Div. 1, Groups E, F, G T4, Class III, Type 4, IP65
• Coaxial/twin rod probes	± 0.5 % of probe length or 0.5 inch (13 mm), whichever is greater	Intrinsically Safe	CSA Class I, Div. 1, Groups A, B, C, D, Class II, Div. 1, Groups E, F, G T4, Class III, Type 4, IP65
• Single rod probes	± 1 inch (25 mm) (distinct Interface required)	Intrinsically Safe (International)	ATEX II 1G EEx ia IIC T4 IECEX Ex ia IIC Ga IECEX DEK 11.00067X
• Interface models	Meets CE requirements (EN 61326-1/2006) (Single and Twin Rod probes must be used in metallic vessel or stilling well to maintain CE compliance.)	Explosion Proof/Flame Proof	FM Class I, Div. 1, Groups B, C, D, Class II, Div. 1, Groups E, F, G T4, Class III, Type 4, IP65
Electromagnetic compatibility	< 1 s		CSA Class I, Div. 1, Groups B, C, D, Class II, Div. 1, Groups E, F, G T4, Class III, Type 4, IP65
• Response time	< 5 s		ATEX II 1/2 G EEx d [ia] IIC T6
• Warm up time	+ 0.02 % of actual probe length/°C for probes ≥ 2.5 m (8 ft)	Non-Incendive	ATEX II 1/2 D IP65 T85 °C FM Class I, Div. 2, Groups A, B, C, D, Class II, Div. 2, Groups F, G T4, Class III, Type 4, IP65
• Temperature Effects		Non-Sparking	CSA Class I, Div. 2, Groups A, B, C, D, Class II, Div. 2, Groups E, F, G T4, Class III, Type 4, IP65
Rated operating conditions ¹⁾			ATEX II 3G EEx nA (nL) IIC T4 ... T6
• Ambient temperature for enclosure	-40 ... +80 °C (-40 ... +176 °F)	Others	ATEX II 3G EEx nA II T4 to T6
• LCD readable temperature range	-20 ... +70 °C (-5 ... +160 °F)		• Functional Safety to SIL-1 in accordance with IEC 61508 Safe Failure Fraction (SFF) of 85.5 % (Third party FMEDA Analysis - hardware only)
• Location	Indoor/outdoor		• Functional Safety to SIL-2 in accordance with IEC 61508 Safe Failure Fraction (SFF) of 91 % (Third party FMEDA Analysis - hardware only)
• Installation category	II		• Lloyds Steam Vessel Approval conforming to EN12952-11 & EN12953-9
• Pollution degree	2		• GOST R
• Humidity	0 ... 99 % (non condensing)		
Medium conditions ¹⁾			
Dielectric constant	dK ≥ 1.4		
Process temperature range ²⁾	-196 ... +427 °C (-321 ... +800 °F)		
Vessel pressure ³⁾	Full vacuum to 431 bar g (6 250 psi g), probe dependent		

¹⁾ If installation is in areas classified as hazardous, please observe relevant certificates

²⁾ Temperature rating is pressure dependent

³⁾ Pressure rating is temperature dependent

Level Measurement

Continuous level measurement – Guided wave radar transmitters

SITRANS LG200

	Coaxial Probe (7ML1301-1)	Coaxial HT/HP Probe (7ML1301-2)	Coaxial HP Probe (7ML1301-3)	Coaxial Overfill/Flooded Cage Probe (7ML1301-4)
Model reference number	7xA-x	7xD-x	7xP-x	7xR-x
Recommended applications	General purpose: clean, low viscosity liquids < 150 °C (300 °F)	Clean, high temperature/ high pressure liquids > 200 °C(400 °F), ammonia, chlorine, LNG ¹ , LPG ¹	Clean, high pressure liquids < 200 °C (400 °F), ammonia, chlorine, LNG, LPG	General applications, overfill, temperatures to 200 °C (400 °F), clean, low viscosity liquids, displacer/torque-tube replacement
Not recommended for:	Coating and buildup, foam	Coating and buildup, foam, steam	Coating and buildup, foam, steam	Coating and buildup, foam
Materials/wetted parts	316 L stainless steel, TFE spacers, O-ring ²	316L stainless steel, Alumina spacers ³ (option PEEK ⁴ or TFE ⁵), Borosilicate	316L stainless steel, TFE spacers, Borosilicate	316L stainless steel, TFE spacers, O-ring ²
Process seal	O-ring ²	Borosilicate (no O-ring)	Borosilicate (no O-ring)	O-ring ²
Rod/tube diameter				
Standard	ø 8 mm (0.3125 inch) rod ø 22 mm (0.875 inch) tube	ø 8 mm (0.3125 inch) rod ø 22 mm (0.875 inch) tube	ø 8 mm (0.3125 inch) rod ø 22 mm (0.875 inch) tube	ø 8 mm (0.3125 inch) rod ø 22 mm (0.875 inch) tube
Enlarged	ø 15 mm (0.63 inch) rod ø 45 mm (1.75 inch) tube	ø 15 mm (0.63 inch) rod ø 45 mm (1.75 inch) tube	ø 15 mm (0.63 inch) rod ø 45 mm (1.75 inch) tube	ø 15 mm (0.63 inch) rod ø 45 mm (1.75 inch) tube
Process connection thread				
Standard	¾" NPT [(Taper), ANSI/ASME B1.20.1], G 1" [(BSPP), EN ISO 228-1]	¾" NPT [(Taper), ANSI/ASME B1.20.1], G 1" [(BSPP), EN ISO 228-1]	¾" NPT [(Taper), ANSI/ASME B1.20.1], G 1" [(BSPP), EN ISO 228-1]	¾" NPT [(Taper), ANSI/ASME B1.20.1], G 1" [(BSPP), EN ISO 228-1]
Enlarged	2" NPT [(Taper), ANSI/ASME B1.20.1]	2" NPT [(Taper), ANSI/ASME B1.20.1]	2" NPT [(Taper), ANSI/ASME B1.20.1]	2" NPT [(Taper), ANSI/ASME B1.20.1]
Flange ASME (EN/DIN)				
Standard	1 ... 4" (DN 25 ... 100)	1 ... 4" (DN 25 ... 100)	1 ... 4" (DN 25 ... 100)	1 ... 4" (DN 25 ... 100)
Enlarged	2 ... 4" (DN 50 ... 100)	2 ... 4" (DN 50 ... 100)	2 ... 4" (DN 50 ... 100)	2 ... 4" (DN 50 ... 100)
Length	60 ... 610 cm (24 ... 240 inch)	60 ... 610 cm (24 ... 240 inch)	60 ... 610 cm (24 ... 240 inch)	60 ... 610 cm (24 ... 240 inch)
Transition Zone⁶				
Top	25 mm (1 inch) at dk = 1.4 150 mm (6 inch) at dk = 80	None	25 mm (1 inch) at dk = 1.4 150 mm (6 inch) at dk = 80	None
Bottom	150 mm (6 inch) at dk = 1.4 25 mm (1 inch) at dk = 80	150 mm (6 inch) at dk = 1.4 25 mm (1 inch) at dk = 80	150 mm (6 inch) at dk = 1.4 25 mm (1 inch) at dk = 80	150 mm (6 inch) at dk = 1.4 25 mm (1 inch) at dk = 80
Process temperature maximum	150 °C at 27 bar g (300 °F at 400 psi g)	427 °C at 133 bar g (800 °F at 2 000 psi g) ⁷	200 °C at 379 bar g (400 °F at 5 500 psi g)	200 °C at 18 bar g (400 °F at 270 psi g)
Process temperature minimum	-40 °C at 70 bar g (-40 °F at 1 000 psi g)	-196 °C at 430 bar g (-321 °F at 6 250 psi g)	-196 °C at 430 bar g (-321 °F at 6 250 psi g)	-40 °C at 70 bar g (-40 °F at 1 000 psi g)
Process pressure				
Process pressure maximum	70 bar g at 20 °C (1 000 psi g at 70 °F)	431 bar g at 20 °C (6 250 psi g at 70 °F)	431 bar g at 20 °C (6 250 psi g at 70 °F)	70 bar g at 20 °C (1 000 psi g at 70 °F)
Process pressure minimum/vacuum service	Yes, not hermetic ⁸	Yes, hermetic (<10 ⁻⁸ cc/sec at 1 atmosphere)	Yes, hermetic (<10 ⁻⁸ cc/sec at 1 atmosphere)	Yes, not hermetic
Dielectric range (dk)	1.4 ... 100	1.4 ... 100 ¹	1.4 ... 100	1.4 ... 100
Maximum viscosity (cP)				
Standard	500	500	500	500
Enlarged	1 500	1 500	1 500	1 500
Coating/buildup	No	No	No	No
Foam	No	No	No	No
Corrosives	Yes	Yes	Yes	Yes
Sanitary	No	No	No	No
Overfill	No	Yes	No	Yes

¹) Dependent on spacer option

²) See O-Ring Selection Guide for guidance

³) For dk ≥ 2, maximum temperature 427 °C (800 °F)

⁴) For dk ≥ 1.4, maximum temperature 343 °C (650 °F), PEEK spacers standard on enlarged coaxial design

⁵) For dk 1.4, maximum temperature 288 °C (550 °F)

⁶) Transition zone is dielectric dependent: dk = dielectric permittivity. Unit will function but accuracy will decrease in Transition Zone

⁷) 345 °C (650 °F) with PEEK spacers

⁸) Not hermetic: sealing by means of O-ring. Hermetic: sealing by means of borosilicate glass window

Level Measurement

Continuous level measurement – Guided wave radar transmitters

SITRANS LG200

	Coaxial Steam Probe (7ML1301-5)	Coaxial Interface Probe (7ML1301-6)	Single Rigid Rod Probe (7ML1303-1)	Single Rigid Rod HT/HP Probe (7ML1303-2)	Single Rigid Rod Probe, PFA rod insulation (7ML1303-1J)
Model reference number	7xS-x	7xT-x	7xF-x	7xJ-x	7xF-4
Recommended applications	Hot water (steam) >200 °C (400 °F) (external chamber is required for use in boilers)	Liquid/liquid-interface, temperatures to 200 °C (400 °F); clean, low-viscosity liquids	Coating and buildup, foam	Coating and buildup, foam	Excessive coating and buildup, foam
Not recommended for	General purpose, coating and buildup, foam	Coating and buildup, foam	Low dielectric media (dK < 10) ¹⁾	Low dielectric media (dK < 10) ¹⁾	Low dielectric media (dK < 10) ¹⁾
Materials/wetted parts	316L stainless steel, PEEK spacers, Aegis PF128 O-ring ²⁾	316L stainless steel, TFE spacers, O-ring ²⁾	316L stainless steel, TFE, O-ring ²⁾	316L stainless steel, TFE, O-ring ²⁾	316L stainless steel, PFA, TFE, O-ring ²⁾
Process seal	Aegis PF128 O-ring ²⁾ , PEEK only	O-ring ²⁾	O-ring ²⁾	Aegis PF128 O-ring only ²⁾	O-ring ²⁾
Rod/Tube diameter:					
Standard	ø 8 mm (0.3125 inch) rod ø 22 mm (0.875 inch) tube	ø 8 mm (0.3125 inch) rod ø 22 mm (0.875 inch) tube	ø 12 mm (0.5 inch) rod	ø 12 mm (0.5 inch) rod	ø 12 mm (0.5 inch) rod ø 16 mm (0.625 inch) insulation
Enlarged	N/A	ø 15 mm (0.63 inch) rod ø 45 mm (1.75 inch) tube	N/A	N/A	N/A
Process connection thread					
Standard	¾" NPT [(Taper), ANSI/ASME B1.20.1], G 1" [(BSPP), EN ISO 228-1]	¾" NPT [(Taper), ANSI/ASME B1.20.1], G 1" [(BSPP), EN ISO 228-1]	¾" NPT [(Taper), ANSI/ASME B1.20.1], G 1" [(BSPP), EN ISO 228-1]	¾" NPT [(Taper), ANSI/ASME B1.20.1], G 1" [(BSPP), EN ISO 228-1]	2" NPT [(Taper), ANSI/ASME B1.20.1], G 2" [(BSPP), EN ISO 228-1]
Enlarged	N/A	2" NPT [(Taper), ANSI/ASME B1.20.1]	N/A	N/A	N/A
Flange ASME (EN/DIN)					
Standard	1 ... 4" (DN 25 ... 100)	1 ... 4" (DN 25 ... 100)	2 ... 4" (DN 50 ... 100)	2 ... 4" (DN 50 ... 100)	2 ... 4" (DN 50 ... 100)
Enlarged	N/A	2 ... 4" (DN 50 ... 100)	N/A	N/A	N/A
Length	60 ... 455 cm (24 ... 180 inch)	60 ... 610 cm (24 ... 240 inch)	60 ... 610 cm (24 ... 240 inch)	60 ... 610 cm (24 ... 240 inch)	60 ... 610 cm (24 ... 240 inch)
Transition Zone³⁾					
Top	25 mm (1 inch) at dk ≥ 10	none	Application, installation, and dielectric dependent	Application, installation, and dielectric dependent	Application, installation, and dielectric dependent
Bottom	25 mm (1 inch) at dk ≥ 10	150 mm (6 inch) at dk = 1.4 25 mm (1 inch) at dk = 80	25 mm (1 inch) at dk >10	25 mm (1 inch) at dk >10	25 mm (1 inch) at dk >10
Process temperature maximum	343 °C at 165 bar g (650 °F at 2 400 psi g) (saturated steam)	200 °C at 18 bar g (400 °F at 270 psi g)	150 °C at 27 bar g (300 °F at 400 psi g)	316 °C at 165 bar g (605 °F at 2 400 psi g)	150 °C at 27 bar g (300 °F at 400 psi g)
Process temperature minimum	-40 °C at 207 bar g (-40 °F at 3 000 psi g)	-40 °C at 70 bar g (-40 °F at 1 000 psi g)	-40 °C at 70 bar g (-40 °F at 1 000 psi g)	-40 °C at 70 bar g (-40 °F at 1 000 psi g)	-40 °C at 50 bar g (-40 °F at 750 psi g)
Process pressure maximum	165 bar g at 343 °C (2 400 psi g at 650 °F)	70 bar g at 20 °C (1 000 psi g at 70 °F)	70 bar g at 20 °C (1 000 psi g at 70 °F)	207 bar g at 20 °C (3 000 psi g at 70 °F)	70 bar g at 20 °C (1 000 psi g at 70 °F)
Process pressure min. vacuum service	Yes, not hermetic	Yes, not hermetic	Not suitable	Not suitable	Not suitable
Dielectric range	10 ... 100	Upper liquid layer 1.4 ... 5 Interface liquid layer 15 ... 100	1.9 ... 100 ¹⁾	1.9 ... 100 ¹⁾	1.9 ... 100 ¹⁾
Maximum viscosity					
Standard	500 cP	500 cP	10 000 cP (consult factory if severe agitation/turbulence)		
Enlarged	N/A	1 500 cP			
Coating/buildup	No	No	Yes, maximum error 10 % of coated length;% error related to dielectric of media, thickness of coating and coated probe length above media		
Foam	No	No	Yes	Yes	Yes
Corrosives	Yes	Yes	Yes	Yes	Yes
Sanitary	No	No	No	No	No
Overfill	Yes	Yes	No	No	No

¹⁾ With dK of 1.9 ... 10, the device must be mounted between 50 and 150 mm (2 ... 6 inch) of metal tank wall or in chamber/bridle

²⁾ See O-ring Selection Guide for guidance

³⁾ Transition zone is dielectric dependent: dK = dielectric permittivity. Unit will function but accuracy will decrease in Transition Zone

Level Measurement

Continuous level measurement – Guided wave radar transmitters

SITRANS LG200

	Single Rigid Rod Probe, Sanitary (7ML1303-1D)	Single Rigid Rod Probe, PFA faced flange(7ML1303-1E)	Single Flexible Rod Probe (7ML1304-1)	Single Flexible Rod Probe for Bulk Solids (7ML1304-2)
Model reference number	7xF-E	7xF-F	7x1-x	7x2-x
Recommended applications:	Applications demanding sanitary specifications	Extreme corrosives, coating/buildup, foam	Coating and buildup, foam; lengths > 6 m (20 ft) headroom	Granular bulk solids applications (powders, grain, dust) 3 000 lb pull down force
Not recommended for	Low dielectric media (dK < 10) ¹⁾	Low dielectric media (dK < 10) ¹⁾	Low dielectric media (dK < 4)	Solids with dK < 4
Materials/wetted parts	316L stainless steel, TFE, 15 µ-inch (<0.4 µm) R _a	All PFA - wetted surfaces	316L stainless steel, TFE, O-ring ²⁾	316L stainless steel, TFE, O-ring ²⁾
Optional	AL6XN stainless steel	N/A	N/A	N/A
Process seal	316L stainless steel, TFE, O-ring ²⁾	PFA, no O-ring	O-ring ²⁾	Sealant
Rod/tube diameter	ø 12 mm (0.5 inch) rod	ø 12 mm (0.5 inch) rod ø 16 mm (0.625 inch) insulation	ø 5 mm (0.188 inch) cable	ø 6 mm (0.25 inch) cable
Process connection thread	N/A	N/A	2" NPT [(Taper), ANSI/ASME B1.20.1], G 2" [(BSPP), EN ISO 228-1]	2" NPT [(Taper), ANSI/ASME B1.20.1], G 2" [(BSPP), EN ISO 228-1]
Flange ASME (DIN)	19 ... 100 mm (¾ ... 4 inch) Triclover-style 16 amp fitting	2 ... 4 inch (DN 50 ... 100)	2 ... 4 inch (DN 50 ... 100)	2 ... 4 inch (DN 50 ... 100)
Length	60 ... 610 cm (24 ... 240 inch)	60 ... 610 cm (24 ... 240 inch)	1 ... 22.5 m (3 ... 75 ft)	1 ... 22.5 m (3 ... 75 ft)
Transition Zone³⁾				
Top	Application, installation, and dielectric dependent	Application, installation, and dielectric dependent	Application, installation, and dielectric dependent	Application, installation, and dielectric dependent
Bottom	25 mm (1 inch) at dk >10	25 mm (1 inch) at dk >10	305 mm (12 inch)	305 mm (12 inch)
Process temperature maximum	150 °C at 5.1 bar g (300 °F at 75 psi g)	150 °C at 27 bar g (300 °F at 400 psi g)	150 °C at 27 bar g (300 °F at 400 psi g)	66 °C at 3.4 bar g (150 °F at 50 psi g)
Process temperature minimum	0 °C at 5.1 bar g (32 °F at 75 psi g)	-40 °C at 13.7 bar g (-40 °F at 200 psi g)	-40 °C at 70 bar g (-40 °F at 1 000 psi g)	-40 °C at 3.4 bar g (-40 °F at 50 psi g)
Process pressure:				
Process pressure maximum	5.1 bar g at 150 °C (75 psi g at 300 °F)	70 bar g at 20 °C (1 000 psi g at 70°F)	70 bar g at 20 °C (1 000 psi g at 70 °F)	3.4 bar g at 66 °C (50 psi g at 150 °F)
Process pressure minimum/vacuum service	Not suitable for vacuum applications			
Dielectric range	1.9 ... 100 ¹⁾	1.9 ... 100 ¹⁾	4 ... 100 ¹⁾	4 ... 100
Maximum viscosity (cP)	10 000 (consult factory if severe agitation/turbulence)			N/A
Coating/buildup	Yes, maximum error 10 % of coated length; % error related to dielectric of media, thickness of coating and coated probe length above media			
Foam	Yes	Yes	Yes	Yes
Corrosives	No	Yes	No	No
Sanitary	Yes	No	No	No
Overfill	No	No	No	No

¹⁾ With dK of 1.9 ... 10, the device must be mounted between 50 and 150 mm (2 ... 6 inch) of metal tank wall or in chamber/bridle

²⁾ See O-ring Selection Guide for guidance

³⁾ Transition zone is dielectric dependent: dK = dielectric permittivity. Unit will function but accuracy will decrease in Transition Zone

Level Measurement

Continuous level measurement – Guided wave radar transmitters

SITRANS LG200

	Twin Rod Probe (7ML1302-1)	Flexible Twin Rod Probe (7ML1302-3)	Flexible Twin Rod Bulk Solids Probe (7ML1302-2)
Model reference number	7xB-x	7x7-x	7x5-x
Recommended applications:	General purpose, foam, minor film coating	Low dielectric media (1.9 ... 10) with lengths > 6 m (20 ft)	Granular light bulk solids applications (powders, grains, dust), 3 000 lb pull-down force
Not recommended for:	Media bridging between rods or building up on spacers	Dielectric > 10: media bridging on flexible elements, dielectrics < 5 with lengths > 10 m (30 ft)	Media bridging flexible elements
Materials/wetted parts	316L stainless steel, TFE spacers, O-ring ¹⁾	316L stainless steel, FEP webbing, O-ring ¹⁾	316L stainless steel, FEP webbing, O-ring ¹⁾
Process seal	O-ring ¹⁾	O-ring ¹⁾	Sealant
Rod/tube diameter	Two, ø 12 mm (0.5 inch) rod; 22 mm (0.875 inch) C _L ... C _L	Two, ø 6 mm (0.25 inch) cables; 22 mm (0.875 inch) C _L ... C _L	Two, ø 6 mm (0.25 inch) cables; 22 mm (0.875 inch) C _L ... C _L
Process connection thread	2" NPT [(Taper), ANSI/ASME B1.20.1], G " [(BSPP), EN ISO 228-1]	2" NPT [(Taper), ANSI/ASME B1.20.1], G 2" [(BSPP), EN ISO 228-1]	2" NPT [(Taper), ANSI/ASME B1.20.1], G 2" [(BSPP), EN ISO 228-1]
Flange ASME (EN/DIN)	2 ... 4" (DN 50 ... 100)	2 ... 4" (DN 50 ... 100)	2 ... 4" (DN 50 ... 100)
Length	60 ... 610 cm (24 ... 240 inch)	1 ... 22.5 m (3 ... 75 ft)	1 ... 22.5 m (3 ... 75 ft)
Transition Zone²⁾:			
Top	150 mm (6 inch) at dK > 1.9 Blocking distance: none	150 mm (6 inch) at dK > 1.9 Blocking distance: 12 ... 50 cm (4.8 ... 20 inch)	150 mm (6 inch) at dK > 1.9 Blocking distance: 12 ... 50 cm (4.8 ... 20 inch)
Bottom	150 mm (6 inch) at dK = 1.9 25 mm (1 inch) at dK = 80	305 mm (12 inch)	305 mm (12 inch)
Process temperature max. ³⁾	200 °C at 19 bar g (400 °F at 275 psi g)		66 °C at 3.4 bar g (150 °F at 50 psi g)
Process temperature min.	-40 °C at 70 bar g (-40 °F at 1 000 psi g)		-40 °C at 3.4 bar g (-40 °F at 50 psi g)
Process pressure max.	70 bar g at 20 °C (1 000 psi g at 70 °F)		3.4 bar g at 66 °C (50 psi g at 150 °F)
Process pressure min./vacuum service	Yes, not hermetic		Not suitable
Dielectric range	1.9 ... 100	1.9 ... 100	1.9 ... 100
Maximum viscosity (cP)	1 500	1 500	Not suitable
Coating/buildup	Yes, maximum error 3 % of coated length with conductive media Bridging not recommended. ⁴⁾		
Foam	Yes	Yes	Yes
Corrosives	Yes	No	Yes
Sanitary	No	No	No
Overfill	No	No	No

¹⁾ See O-ring Selection Guide for guidance

²⁾ Transition zone is dielectric dependent: dK = dielectric permittivity. Unit will function but accuracy will decrease in Transition Zone

³⁾ Refer to Ambient Temperature vs Process Temperature graphs or instruction manual

⁴⁾ Bridging is defined as continuous accumulation of material between the probe elements

O-ring and Seal Selection Guide

Material	Recommended for Use in:	Not Recommended for Use In:
Viton GFLT	General purpose, steam, ethylene	Ketones (MEK, acetone), skydrol fluids, amines, anhydrous ammonia, low molecular weight esters and ethers, hot hydrofluoric or chlorosulfuric acids, sour HCs
EPDM	Acetone, MEK, skydrol fluids	Petroleum oils, di-ester base lubricants, propane, steam, anhydrous ammonia
Kalrez (4079)	Inorganic and organic acids (including HF and nitric) aldehydes, ethylene, glycols, organic oils, silicone oils, vinegar, sour HCs	Black liquor, hot water/steam, hot aliphatic amines, ethylene oxide, propylene oxide, molten sodium, molten potassium, anhydrous ammonia
Aegis PF128	Inorganic and organic acids (including HF and nitric) aldehydes, ethylene, glycols, organic oils, silicone oils, vinegar, sour HCs, steam, amines, ethylene oxide, propylene oxide	Black liquor, Freon 43, Freon 75, Galden, KEL-F liquid, molten sodium, molten potassium, anhydrous ammonia
Borosilicate (HT/HP probes only)	General high temperature/high pressure applications, hydrocarbons, full vacuum (hermetic), anhydrous ammonia	Steam, hot alkaline solutions, HF acid, media with pH>12, condensate

Level Measurement

Continuous level measurement – Guided wave radar transmitters

SITRANS LG200

Selection and Ordering data

SITRANS LG200 Transmitter

A guided wave radar transmitter for short and medium range level, level/interface, and volume measurement of liquids and solids, including high temperature and pressure applications, and steam.

Note:

In addition to the transmitter, please select a probe configuration to complete the SITRANS LG200 (ordered separately).

For orders of 10 or more, please consult factory.

Power

24 V DC, 2-wire

Signal Output

4 ... 20 mA HART

Options

SIL-1 Approved (FMEDA analysis) SFF = 85.5 %

SIL-2 Approved (FMEDA analysis) SFF = 91 %

Enclosure/lid

Aluminum

Aluminum with glass window

Cable inlet

2 x ½" NPT, IP65

2 x M20x1.5, IP65

Approvals (Please select for your region)

North America

General Purpose and Intrinsically Safe (CSA/FM Class I, Div. 1, Groups A, B, C, D; Class II, Div. 1, Groups E, F, G T4, Class III); Non-incendive (CSA Class I, Div. 2, Groups A, B, C, D, Class II, Div. 2, Groups E, F, G; FM Class I, Div. 2, Groups A, B, C, D, Class II, Div. 2, Groups F, G)

Explosion Proof (CSA/FM Class I, Div. 1, Groups B, C, and D; Class II, Div. 1, Groups E, F, G, T4; Class III); Non-incendive (CSA Class I, Div. 2, Groups A, B, C, D, Class II, Div. 2, Groups E, F, G; FM Class I, Div. 2, Groups A, B, C, D, Class II, Div. 2, Groups F, G)

Europe

General Purpose and Intrinsically Safe (ATEX II 1G EEx ia IIC T4); IECEx Ex ia IIC T4 Ga

Explosion Proof (ATEX II 1/2 GD EEx d [ia] IIC T6)

Non-sparking [ATEX II 3G EEx nA II/EEx nA (nL) IIC T4 to T6]

Article No.

7ML1300-

1 - A 0

1

A

A

B

1

2

0

1

A

B

C

D

E

Selection and Ordering data

Further designs

Please add "-Z" to Article No. and specify Order code(s).

Manufacturer's test certificate: M to DIN 55350, Part 18 and to ISO 9000 [Available only when ordered in conjunction with a probe (7ML130x-x). Testing requires transmitter with probe.]

Operating Instructions

English

French

German

Multi-language Quick Start manual

This device is shipped with the Siemens Milltronics manual DVD containing the ATEX Quick Start and Operating Instructions library.

Accessories

SITRANS RD100 Remote display - see Chapter 7

SITRANS RD200 Remote display - see Chapter 7

SITRANS RD500 web, datalogging, alarming, ethernet, and modem support for instrumentation - see Chapter 7

For applicable back up point level switch - see point level section on page 4/9

Order code

C11

Article No.

7ML1998-5KA02

7ML1998-5KA11

7ML1998-5KA32

7ML1998-5XG81

7ML5750-1AA00-0

Level Measurement

Continuous level measurement – Guided wave radar transmitters

SITRANS LG200

Selection and Ordering data	Article No.	Selection and Ordering data	Article No.
SITRANS LG200 Coaxial Probes	7ML1301-	SITRANS LG200 Coaxial Probes	7ML1301-
SITRANS LG200 coaxial probes are used in most standard applications. Coaxial probes yield robust signal strength even in extremely low dielectric applications (dK 1.4 ... 100).	0	SITRANS LG200 coaxial probes are used in most standard applications. Coaxial probes yield robust signal strength even in extremely low dielectric applications (dK 1.4 ... 100).	0
Note: In addition to the probe, please select a transmitter configuration to complete the SITRANS LG200 (ordered separately). For orders of 10 or more, please consult factory.		<u>Add Order code Y01 and plain text:</u> <u>"Insertion length ... cm"</u>	
Model		Model options 3, 6 with Material of Construction option E: 60 ... 100 cm (23.6 ... 39.4 inch)	C 1
Coaxial ^{1) 2)}	1	Model options 3, 6 with Material of Construction option E: 101 ... 200 cm (39.8 ... 78.7 inch)	C 2
Coaxial, High Temperature/High Pressure ²⁾³⁾	2	Model options 3, 6 with Material of Construction option E: 201 ... 300 cm (79.1 ... 118.1 inch)	C 3
Coaxial, High Pressure ²⁾³⁾	3	Model options 3, 6 with Material of Construction option E: 301 ... 400 cm (118.5 ... 157.5 inch)	C 4
Coaxial, Overfill/Flooded Cage ¹⁾²⁾	4	Model options 3, 6 with Material of Construction option E: 401 ... 500 cm (157.9 ... 196.9 inch)	C 5
Coaxial Steam ⁴⁾⁵⁾	5	Model options 3, 6 with Material of Construction option E: 501 ... 610 cm (197.2 ... 240.2 inch)	C 6
Coaxial, Interface ¹⁾²⁾	6	<u>Add Order code Y01 and plain text:</u> <u>"Insertion length ... cm"</u>	
Material of Construction		Model option 2 with Material of Construction options A, E, H, J: 60 ... 100 cm (23.6 ... 39.4 inch)	E 1
316/316L (1.4401/1.4404) stainless steel probe and process connection	A	Model option 2 with Material of Construction options A, E, H, J: 101 ... 200 cm (39.8 ... 78.7 inch)	E 2
316/316L (1.4401/1.4404) stainless steel probe ASME B31.1 specifications ⁶⁾	D	Model option 2 with Material of Construction options A, E, H, J: 201 ... 300 cm (79.1 ... 118.1 inch)	E 3
Enlarged Coaxial, 316/316L (1.4401/1.4404) stainless steel probe and process connection with PEEK Spacers ⁷⁾	E	Model option 2 with Material of Construction options A, E, H, J: 301 ... 400 cm (118.5 ... 157.5 inch)	E 4
316/316L (1.4401/1.4404) stainless steel probe and process connection with PEEK HT spacers dk ≥ 1.4 ⁸⁾	H	Model option 2 with Material of Construction options A, E, H, J: 401 ... 500 cm (157.9 ... 196.9 inch)	E 5
316/316L (1.4401/1.4404) stainless steel probe and process connection with Teflon spacers dk ≥ 2 ⁸⁾⁹⁾	J	Model option 2 with Material of Construction options A, E, H, J: 501 ... 610 cm (197.2 ... 240.2 inch)	E 6
Probe Insertion Length		Add Order code Y01 and plain text: "Insertion length ... cm"	
Add Order code Y01 and plain text: "Insertion length ... mm"		Model option 5 with Material of Construction options A, D: 60 ... 100 cm (23.6 ... 39.4 inch)	F 1
Model option 1, 4 and Material of Construction option A, E: 60 ... 100 cm (23.6 ... 39.4 inch)	A 1	Model option 5 with Material of Construction options A, D: 101 ... 200 cm (39.8 ... 78.7 inch)	F 2
Model option 1, 4 and Material of Construction option A, E: 101 ... 200 cm (39.8 ... 78.7 inch)	A 2	Model option 5 with Material of Construction options A, D: 201 ... 300 cm (79.1 ... 118.1 inch)	F 3
Model option 1, 4 and Material of Construction option A, E: 201 ... 300 cm (79.1 ... 118.1 inch)	A 3	Model option 5 with Material of Construction options A, D: 301 ... 400 cm (118.5 ... 157.5 inch)	F 4
Model option 1, 4 and Material of Construction option A, E: 301 ... 400 cm (118.5 ... 157.5 inch)	A 4	Model option 5 with Material of Construction options A, D: 401 ... 500 cm (157.9 ... 196.9 inch)	F 5
Model option 1, 4 and Material of Construction option A, E: 401 ... 500 cm (157.9 ... 196.9 inch)	A 5		
Model option 1, 4 and Material of Construction option A, E: 501 ... 610 cm (197.2 ... 240.2 inch)	A 6		
<u>Add Order code Y01 and plain text:</u> <u>"Insertion length ... cm"</u>		O-rings	
Model options 3, 6 with Material of Construction option A: 60 ... 100 cm (23.6 ... 39.4 inch)	B 1	Viton	1 1
Model options 3, 6 with Material of Construction option A: 101 ... 200 cm (39.8 ... 78.7 inch)	B 2	EPDM (Ethylene Propylene Rubber)	1 2
Model options 3, 6 with Material of Construction option A: 201 ... 300 cm (79.1 ... 118.1 inch)	B 3	Kalrez 4079	1 3
Model options 3, 6 with Material of Construction option A: 301 ... 400 cm (118.5 ... 157.5 inch)	B 4	HSN (Nitrile)	1 4
Model options 3, 6 with Material of Construction option A: 401 ... 500 cm (157.9 ... 196.9 inch)	B 5	Buna-N	1 5
Model options 3, 6 with Material of Construction option A: 501 ... 610 cm (197.2 ... 240.2 inch)	B 6	Neoprene	1 6
		Chemraz	1 7
		Polyurethane	1 8
		Aegis PF128 (can be used on steam applications)	2 1
		Kalrez 2035	2 2
		None (Borosilicate glass seal, not for steam applications) ¹⁰⁾	2 3

Level Measurement

Continuous level measurement – Guided wave radar transmitters

SITRANS LG200

Selection and Ordering data

Article No.

SITRANS LG200 Coaxial Probes

7ML1301-

SITRANS LG200 coaxial probes are used in most standard applications. Coaxial probes yield robust signal strength even in extremely low dielectric applications (dK 1.4 ... 100).



Process Connection (Size/Type)

Threaded

¾" NPT [(Taper), ANSI/ASME B1.20.1]

AA

G 1" [(BSPP), EN ISO 228-1]

AB

G 2" [(BSPP), EN ISO 228-1]¹¹⁾

AC

2" NPT [(Taper), ANSI/ASME B1.20.1]¹⁾

AD

ASME flanges

1" 150 lb ASME raised face flange

BA

1" 300 lb ASME raised face flange

BB

1" 600 lb ASME raised face flange

BC

1" 900/1 500 lb ASME raised face flange¹⁰⁾

BD

1" 2 500 lb ASME raised face flange¹⁰⁾

BE

1" 900/1 500 lb ASME ring joint flange¹⁰⁾

BF

1" 2 500 lb ASME ring joint flange¹⁰⁾

BG

1½" 150 lb ASME raised face flange

CA

1½" 300 lb ASME raised face flange

CB

1½" 600 lb ASME raised face flange

CC

1½" 900/1 500 lb ASME raised face flange¹⁰⁾

CD

1½" 2 500 lb ASME raised face flange¹⁰⁾

CE

1½" 600 lb ASME ring joint flange

CF

1½" 900/1 500 lb ASME ring joint flange¹⁰⁾

CG

1½" 2 500 lb ASME ring joint flange¹⁰⁾

CH

2" 150 lb ASME raised face flange

DA

2" 300 lb ASME raised face flange

DB

2" 600 lb ASME raised face flange

DC

2" 900/1 500 lb ASME raised face flange¹⁰⁾

DD

2" 2 500 lb ASME raised face flange¹⁰⁾

DE

2" 600 lb ASME ring joint flange

DF

2" 900/1 500 lb ASME ring joint flange¹⁰⁾

DG

2" 2 500 lb ASME ring joint flange¹⁰⁾

DH

3" 150 lb ASME raised face flange

EA

3" 300 lb ASME raised face flange

EB

3" 600 lb ASME raised face flange

EC

3" 900 lb ASME raised face flange¹⁰⁾

ED

3" 1 500 lb ASME raised face flange¹⁰⁾

EE

3" 2 500 lb ASME raised face flange¹⁰⁾

EF

3" 600 lb ASME ring joint flange

EG

3" 900 lb ASME ring joint flange¹⁰⁾

EH

3" 1 500 lb ASME ring joint flange¹⁰⁾

EJ

3" 2 500 lb ASME ring joint flange¹⁰⁾

EK

4" 150 lb ASME raised face flange

FA

4" 300 lb ASME raised face flange

FB

4" 600 lb ASME raised face flange

FC

4" 900 lb ASME raised face flange¹⁰⁾

FD

4" 1 500 lb ASME raised face flange¹⁰⁾

FE

4" 2 500 lb ASME raised face flange¹⁰⁾

FF

4" 600 lb ASME ring type joint flange

FG

4" 900 lb ASME ring type joint flange¹⁰⁾

FH

4" 1 500 lb ASME ring type joint flange¹⁰⁾

FJ

4" 2 500 lb ASME ring type joint flange¹⁰⁾

FK

Selection and Ordering data

Article No.

SITRANS LG200 Coaxial Probes

7ML1301-

SITRANS LG200 coaxial probes are used in most standard applications. Coaxial probes yield robust signal strength even in extremely low dielectric applications (dK 1.4 ... 100).



EN flanges

DN 25 PN 16 EN 1092-1

GA

Type A flat faced flange

DN 25 PN 25/40 EN 1092-1

GB

Type A flat faced flange

DN 25 PN 64/100 EN 1092-1

GC

Type B2 raised faced flange

DN 25 PN 160 EN 1092-1

GD

Type B2 raised faced flange¹⁰⁾

DN 25 PN 250 EN 1092-1

GE

Type B2 raised faced flange¹⁰⁾

DN 25 PN 320 EN 1092-1

GF

Type B2 raised faced flange¹⁰⁾

DN 25 PN 400 EN 1092-1

GG

Type B2 raised faced flange¹⁰⁾

DN 40 PN 16 EN 1092-1

HA

Type A flat faced flange

DN 40 PN 25/40 EN 1092-1

HB

Type A flat faced flange

DN 40 PN 64/100 EN 1092-1

HC

Type B2 raised faced flange

DN 40 PN 160 EN 1092-1

HD

Type B2 raised faced flange¹⁰⁾

DN 40 PN 250 EN 1092-1

HE

Type B2 raised faced flange¹⁰⁾

DN 40 PN 320 EN 1092-1

HF

Type B2 raised faced flange¹⁰⁾

DN 40 PN 400 EN 1092-1

HG

Type B2 raised faced flange¹⁰⁾

DN 50 PN 16 EN 1092-1

JA

Type A flat faced flange

DN 50 PN 25/40 EN 1092-1

JB

Type A flat faced flange

DN 50 PN 64 EN 1092-1

JC

Type B2 raised faced flange

DN 50 PN 100 EN 1092-1

JD

Type B2 raised faced flange

DN 50 PN 160 EN 1092-1

JE

Type B2 raised faced flange¹⁰⁾

DN 50 PN 250 EN 1092-1

JF

Type B2 raised faced flange¹⁰⁾

DN 50 PN 320 EN 1092-1

JG

Type B2 raised faced flange¹⁰⁾

DN 50 PN 400 EN 1092-1

JH

Type B2 raised faced flange¹⁰⁾

DN 80 PN 16 EN 1092-1

KA

Type A flat faced flange

DN 80 PN 25/40 EN 1092-1

KB

Type A flat faced flange

DN 80 PN 64 EN 1092-1

KC

Type B2 raised faced flange

DN 80 PN 100 EN 1092-1

KD

Type B2 raised faced flange

DN 80 PN 160 EN 1092-1

KE

Type B2 raised faced flange¹⁰⁾

DN 80 PN 250 EN 1092-1

KF

Type B2 raised faced flange¹⁰⁾

DN 80 PN 320 EN 1092-1

KG

Type B2 raised faced flange¹⁰⁾

DN 80 PN 400 EN 1092-1

KH

Type B2 raised faced flange¹⁰⁾

Level Measurement

Continuous level measurement – Guided wave radar transmitters

SITRANS LG200

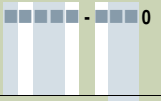
Selection and Ordering data	Article No.	Selection and Ordering data	Order code
SITRANS LG200 Coaxial Probes	7ML1301-	Further designs	
SITRANS LG200 coaxial probes are used in most standard applications. Coaxial probes yield robust signal strength even in extremely low dielectric applications (dK 1.4 ... 100).		Please add "-Z" to Article No. and specify Order code(s).	
DN 100 PN 16 EN 1092-1 Type A flat faced flange	LA	Enter the total insertion length in plain text description, max. 610 cm (240.2 inch)	Y01
DN 100 PN 25/40 EN 1092-1 Type A flat faced flange	LB	Stainless steel tag. Measuring-point number/ identification (max. 27 characters); specify in plain text	Y15
DN 100 PN 64 EN 1092-1 Type B2 raised faced flange	LC	Inspection Certificate Type 3.1 per EN 10204	C12
DN 100 PN 100 EN 1092-1 Type B2 raised faced flange	LD	Manufacturer's test report (Hydrostatic Test)	C18
DN 100 PN 160 EN 1092-1 Type B2 raised faced flange ¹⁰⁾	LE	NACE MR-0175 materials traceability	D07
DN 100 PN 250 EN 1092-1 Type B2 raised faced flange ¹⁰⁾	LF	Operating Instructions	Article No.
DN 100 PN 320 EN 1092-1 Type B2 raised faced flange ¹⁰⁾	LG	English	7ML1998-5KA02
DN 100 PN 400 EN 1092-1 Type B2 raised faced flange ¹⁰⁾	LH	French	7ML1998-5KA11
Fisher torque tube flange, carbon steel (249B)	MA	German	7ML1998-5KA32
Fisher torque tube flange, 316 stainless steel (249C)	MB	Multi-language Quick Start manual This device is shipped with the Siemens Milltronics manual DVD containing the ATEX Quick Start and Operating Instructions library.	7ML1998-5XG81
Masoniail torque tube flange, carbon steel	MC	Accessories	
Masoniail torque tube flange, 316 stainless steel	MD	Kit, spacer coax probe with parts	A5E03523523
		SITRANS RD100 Remote display - see Chapter 7	
		SITRANS RD200 Remote display - see Chapter 7	
		SITRANS RD500 web, datalogging, alarming, ethernet, and modem support for instrumentation - see Chapter 7	7ML5750-1AA00-0

- 1) Not available with O-ring option 21 (type Aegis PF128)
- 2) Consult factory for these options in Hastelloy C or Monel
- 3) Available with O-ring option 23 only (none)
- 4) Coaxial steam probe must be used with O-ring option 21 only (type Aegis PF128)
- 5) Available with Material of Construction option A and D only [316/316L (1.4401/1.4404) stainless steel]
- 6) Available with Model option 5 only (coaxial steam probe)
- 7) 2" or DN 50 minimum Process Connection and available with PEEK Spacers for temperature maximum 345 °C (650 °F)
- 8) Used with Model option 2 only (coaxial High Temperature/High Pressure probe)
- 9) Process temperature maximum 345 °C (650 °F)
- 10) Available with model options 2, 3, and 5 only (High Temperature/High Pressure, High Pressure, and Steam probes only)
- 11) Available with Material of Construction option E only (enlarged coaxial probe)

Level Measurement

Continuous level measurement – Guided wave radar transmitters

SITRANS LG200

Selection and Ordering data

Article No.

SITRANS LG200 Twin Rod Probes

7ML1302-

SITRANS LG200 twin rod probes are used in applications where coating and buildup are possible. Used in application with dielectric constant ≥ 1.9 .

Note:

In addition to the probe, please select a transmitter configuration to complete the SITRANS LG200 (ordered separately).

For orders of 10 or more, please consult factory.

Model

Twin rigid rod 1
Flexible twin rod bulk solids probe¹⁾ 2
Flexible twin rod probe²⁾ 3

Material of Construction

316/316L (1.4401/1.4404) stainless steel probe and process connection A

Process Connection (size/type)

2" NPT [(Taper), ANSI/ASME B1.20.1] A 1
G 2" [(BSPP), EN ISO 228-1] A 2
2" 150 lb ASME raised face flange³⁾ A 3
2" 300 lb ASME raised face flange³⁾ B 1
3" 150 lb ASME raised face flange B 2
2" 600 lb ASME raised face flange B 3
3" 300 lb ASME raised face flange C 1
4" 150 lb ASME raised face flange C 2
3" 600 lb ASME raised face flange C 3
4" 300 lb ASME raised face flange D 1
DN 50 PN 16 EN 1092-1 D 2
Type A flat faced flange D 3
4" 600 lb ASME raised face flange D 3
DN 50 PN 25/40 EN 1092-1 E 1
Type A flat faced flange E 2
DN 80 PN 16 EN 1092-1 E 2
Type A flat faced flange E 3
DN 80 PN 25/40 EN 1092-1 E 3
Type A flat faced flange E 4
DN 100 PN 16 EN 1092-1 E 4
Type A flat faced flange E 5
DN 100 PN 25/40 EN 1092-1 E 5
Type A flat faced flange E 5
Fisher Torque Tube flange, 316 stainless steel (249C) F 1
Masoneilan Torque Tube flange, 316 stainless steel G 1
Carbon steel
Fisher Torque Tube flange, Carbon steel (249B) K 1
Masoneilan Torque Tube flange, Carbon steel L 1

O-ring

Viton 1 1
EPDM (Ethylene Propylene Rubber) 1 2
Kalrez 4079 1 3
HSN (Nitrile) 1 4
Buna-N 1 5
Neoprene 1 6
Chemraz 1 7
Polyurethane 1 8
Aegis PF128 2 1
Kalrez 2035 2 2

Probe Insertion Length

Add Order code Y01 and plain text:
"Insertion length ... cm"

Model option 1 and Material of Construction option A: 60 ... 100 cm (23.6 ... 39.4 inch) AA
Model option 1 and Material of Construction option A: 101 ... 200 cm (39.8 ... 78.7 inch) AB
Model option 1 and Material of Construction option A: 201 ... 300 cm (79.1 ... 118.1 inch) AC

Selection and Ordering data

Article No.

SITRANS LG200 Twin Rod Probes

7ML1302-

SITRANS LG200 twin rod probes are used in applications where coating and buildup are possible. Used in application with dielectric constant ≥ 1.9 .

Model option 1 and Material of Construction option A: 301 ... 400 cm (118.5 ... 157.5 inch) AD
Model option 1 and Material of Construction option A: 401 ... 500 cm (157.9 ... 196.9 inch) AE
Model option 1 and Material of Construction option A: 501 ... 610 cm (197.2 ... 240.2 inch) AF

Standard lengths⁴⁾

Model option 2,3 and Material of Construction option A: 1 m (39.4 inch) EA
Model option 2,3 and Material of Construction option A: 2 m (78.7 inch) EB
Model option 2,3 and Material of Construction option A: 3 m (118.1 inch) EC
Model option 2,3 and Material of Construction option A: 4 m (157.5 inch) ED
Model option 2,3 and Material of Construction option A: 5 m (196.9 inch) EE
Model option 2,3 and Material of Construction option A: 6 m (236.2 inch) EF
Model option 2,3 and Material of Construction option A: 7 m (275.6 inch) EG
Model option 2,3 and Material of Construction option A: 8 m (315.0 inch) EH
Model option 2,3 and Material of Construction option A: 9 m (354.3 inch) EJ
Model option 2,3 and Material of Construction option A: 10 m (393.7 inch)²⁾³⁾ EK
Model option 2,3 and Material of Construction option A: 11 m (433.1 inch)²⁾³⁾ EL
Model option 2,3 and Material of Construction option A: 12 m (472.4 inch)²⁾³⁾ EM
Model option 2,3 and Material of Construction option A: 13 m (511.8 inch)²⁾³⁾ EN
Model option 2,3 and Material of Construction option A: 14 m (551.2 inch)²⁾³⁾ EP
Model option 2,3 and Material of Construction option A: 15 m (590.6 inch)²⁾³⁾ EQ
Model option 2,3 and Material of Construction option A: 16 m (629.9 inch)²⁾³⁾ ER
Model option 2,3 and Material of Construction option A: 17 m (669.3 inch)²⁾³⁾ ES
Model option 2,3 and Material of Construction option A: 18 m (708.7 inch)²⁾³⁾ ET
Model option 2,3 and Material of Construction option A: 19 m (748.0 inch)²⁾³⁾ EU
Model option 2,3 and Material of Construction option A: 20 m (787.4 inch)²⁾³⁾ EV
Model option 2,3 and Material of Construction option A: 21 m (826.8 inch)²⁾³⁾ EW
Model option 2,3 and Material of Construction option A: 22.5 m (885.8 inch)²⁾³⁾ EX

¹⁾ Available with O-ring 11 only

²⁾ When used with model option 3, not suitable for $dk < 5$

³⁾ Available with model option 1 only

⁴⁾ No Y01 needed in Order code

Level Measurement

Continuous level measurement – Guided wave radar transmitters

SITRANS LG200

Selection and Ordering data	Order code
Further designs	
Please add "-Z" to Article No. and specify Order code(s).	
Enter the total insertion length in plain text description, max. 610 cm (240.2 inch)	Y01
Stainless steel tag. Measuring-point number/ identification (max. 27 characters); specify in plain text	Y15
Inspection Certificate Type 3.1 per EN 10204	C12
Manufacturer's test report (Hydrostatic Test)	C18
NACE MR-0175 materials traceability	D07
Operating Instructions	
English	Article No. 7ML1998-5KA02
French	7ML1998-5KA11
German	7ML1998-5KA32
Multi-language Quick Start manual This device is shipped with the Siemens Milltronics manual DVD containing the ATEX Quick Start and Operating Instructions library.	7ML1998-5XG81
Accessories	
SITRANS RD100 Remote display - see Chapter 7	
SITRANS RD200 Remote display - see Chapter 7	
SITRANS RD500 web, datalogging, alarming, ethernet, and modem support for instrumentation - see Chapter 7	7ML5750-1AA00-0

Level Measurement

Continuous level measurement – Guided wave radar transmitters

SITRANS LG200

Selection and Ordering data

Article No.

SITRANS LG200 Single Rod Rigid Probes

7ML1303-

SITRANS LG200 single rod rigid probes are used in applications where coating and buildup are likely. Used in applications with dielectric constant ≥ 10 , or $dk > 1.9$ when installed within 2 ... 6 inch of a metal tank wall or in cage or bridle.

Note:

In addition to the probe, please select a transmitter configuration to complete the SITRANS LG200 (ordered separately).

For orders of 10 or more, please consult factory.

Model

Single rod rigid probe¹⁾

1

High Temperature/High Pressure Single rod²⁾⁽³⁾

2

Material of Construction

316/316L (1.4401/1.4404) stainless steel probe and process connection

A

316/316L (1.4401/1.4404) stainless steel sanitary probe and process connection¹⁾⁽⁴⁾

D

PFA faced-flange and rod insulation, all PFA wetted parts (316 stainless steel rod)¹⁾⁽⁵⁾

E

316 AL6XN stainless steel sanitary probe and process connection¹⁾⁽⁶⁾

F

PFA rod insulation

J

(316 stainless steel rod and process connection)

Process Connection (size/type)

1 or 1½" Tri-Clover 16 amp sanitary fitting⁷⁾

A 1

2" NPT [(Taper), ANSI/ASME B1.20.1]⁸⁾

A 2

G 2" [(BSPP), EN ISO 228-1]⁸⁾

A 3

2" 150 lb ASME raised face flange⁸⁾

A 4

2" 300 lb ASME raised face flange⁸⁾

A 5

2" Tri-Clover 16 amp sanitary fitting⁷⁾

A 6

¾" Tri-Clover 16 amp sanitary fitting^{7) 9)}

A 7

2½" Tri-Clover 16 amp sanitary fitting⁷⁾

B 0

3" 150 lb ASME raised face flange⁸⁾

B 1

3" 300 lb ASME raised face flange⁸⁾

B 2

3" Tri-Clover 16 amp sanitary fitting⁷⁾

B 3

4" 150 lb ASME raised face flange⁸⁾

C 1

4" 300 lb ASME raised face flange⁸⁾

C 2

4" Tri-Clover 16 amp sanitary fitting⁷⁾

C 3

DN 50, PN 16, EN 1092-1

D 1

Type A flat faced flange⁸⁾

DN 50, PN 25/40, EN 1092-1

D 2

Type A flat faced flange⁸⁾

DN 80, PN 16, EN 1092-1

D 3

Type A flat faced flange⁸⁾

DN 80, PN 25/40, EN 1092-1

D 4

Type A flat faced flange⁸⁾

DN 100, PN 16, EN 1092-1

D 5

Type A flat faced flange⁸⁾

DN 100, PN 25/40, EN 1092-1

D 6

Type A flat faced flange⁸⁾

Selection and Ordering data

Article No.

SITRANS LG200 Single Rod Rigid Probes

7ML1303-

SITRANS LG200 single rod rigid probes are used in applications where coating and buildup are likely. Used in applications with dielectric constant ≥ 10 , or $dk > 1.9$ when installed within 2 ... 6 inch of a metal tank wall or in cage or bridle.

AL6XN¹⁰⁾

¾" Tri-Clover 16 amp sanitary fitting⁹⁾⁽¹⁰⁾

E 0

1½" Tri-Clover 16 amp sanitary fitting¹⁰⁾

E 1

2" Tri-Clover 16 amp sanitary fitting¹⁰⁾

E 2

2½" Tri-Clover 16 amp sanitary fitting¹⁰⁾

E 3

3" Tri-Clover 16 amp sanitary fitting¹⁰⁾

F 1

4" Tri-Clover 16 amp sanitary fitting¹⁰⁾

G 1

PFA Coated 316 stainless steel flange¹¹⁾2" 150 lb ASME raised face flange¹¹⁾

H 1

2" 300 lb ASME raised face flange¹¹⁾

H 2

3" 150 lb ASME raised face flange¹¹⁾

J 1

3" 300 lb ASME raised face flange¹¹⁾

J 2

4" 150 lb ASME raised face flange¹¹⁾

K 1

4" 300 lb ASME raised face flange¹¹⁾

K 2

DN 50, PN 16, EN 1092-1

L 1

Type A flat faced flange¹¹⁾

DN 50, PN 25/40, EN 1092-1

L 2

Type A flat faced flange¹¹⁾

DN 80, PN 16, EN 1092-1

L 3

Type A flat faced flange¹¹⁾

DN 80, PN 25/40, EN 1092-1

L 4

Type A flat faced flange¹¹⁾

DN 100, PN 16, EN 1092-1

L 5

Type A flat faced flange¹¹⁾

DN 100, PN 25/40, EN 1092-1



L 6

Type A flat faced flange¹¹⁾

Level Measurement

Continuous level measurement – Guided wave radar transmitters

SITRANS LG200

Selection and Ordering data	Article No.	Selection and Ordering data	Article No.
SITRANS LG200 Single Rod Rigid Probes SITRANS LG200 single rod rigid probes are used in applications where coating and buildup are likely. Used in applications with dielectric constant ≥ 10 , or $dk > 1.9$ when installed within 2 ... 6 inch of a metal tank wall or in cage or bridle.	7ML1303- 	SITRANS LG200 Single Rod Rigid Probes SITRANS LG200 single rod rigid probes are used in applications where coating and buildup are likely. Used in applications with dielectric constant ≥ 10 , or $dk > 1.9$ when installed within 2 ... 6 inch of a metal tank wall or in cage or bridle.	7ML1303- 
Higher Pressure rated flanges <u>ANSI/ASME</u> 2" 600 lb ASME raised face flange ⁸⁾ 2" 900/1 500 lb ASME raised face flange ¹²⁾ 2" 2 500 lb ASME raised face flange ¹²⁾ 3" 600 lb ASME raised face flange ⁸⁾ 3" 900 lb ASME raised face flange ¹²⁾ 3" 1 500 lb ASME raised face flange ¹²⁾ 3" 2 500 lb ASME raised face flange ¹²⁾ 4" 600 lb ASME raised face flange ⁸⁾ 4" 900 lb ASME raised face flange ¹²⁾ 4" 1 500 lb ASME raised face flange ¹²⁾ 4" 2 500 lb ASME raised face flange ¹²⁾ 2" 600 lb ASME ring type joint flange ⁸⁾ 2" 900/1 500 lb ASME ring type joint flange ¹²⁾ 2" 2 500 lb ASME ring type joint flange ¹²⁾ 3" 600 lb ASME ring type joint flange ⁸⁾ 3" 900 lb ASME ring type joint flange ¹²⁾ 3" 1 500 lb ASME ring type joint flange ¹²⁾ 3" 2 500 lb ASME ring type joint flange ¹²⁾ 4" 600 lb ASME ring type joint flange ⁸⁾ 4" 900 lb ASME ring type joint flange ¹²⁾ 4" 1 500 lb ASME ring type joint flange ¹²⁾ 4" 2 500 lb ASME ring type joint flange ¹²⁾	M 0 M 1 M 2 N 0 N 3 N 4 N 5 P 0 P 3 P 4 P 5 Q 0 Q 1 Q 2 R 0 R 3 R 4 R 5 S 0 S 3 S 4 S 5	<u>EN flanges</u> DN 50, PN 64, EN 1092-1 Type B2 raised faced flange ⁸⁾ DN 50, PN 100, EN 1092-1 Type B2 raised faced flange ⁸⁾ DN 50, PN 160, EN 1092-1 Type B2 raised faced flange ¹²⁾ DN 50, PN 250, EN 1092-1 Type B2 raised faced flange ¹²⁾ DN 80, PN 64, EN 1092-1 Type B2 raised faced flange ⁸⁾ DN 80, PN 100, EN 1092-1 Type B2 raised faced flange ⁸⁾ DN 80, PN 160, EN 1092-1 Type B2 raised faced flange ¹²⁾ DN 80, PN 250, EN 1092-1 Type B2 raised faced flange ¹²⁾ DN 100, PN 64, EN 1092-1 Type B2 raised faced flange ⁸⁾ DN 100, PN 100, EN 1092-1 Type B2 raised faced flange ⁸⁾ DN 100, PN 160, EN 1092-1 Type B2 raised faced flange ¹²⁾ DN 100, PN 250, EN 1092-1 Type B2 raised faced flange ¹²⁾	T 0 T 1 T 2 T 3 U 0 U 1 U 2 U 3 V 0 V 1 V 2 V 3

Level Measurement

Continuous level measurement – Guided wave radar transmitters

SITRANS LG200

Selection and Ordering data

Article No.

SITRANS LG200 Single Rod Rigid Probes

7ML1303-

SITRANS LG200 single rod rigid probes are used in applications where coating and buildup are likely. Used in applications with dielectric constant ≥ 10 , or $dk > 1.9$ when installed within 2 ... 6 inch of a metal tank wall or in cage or bridle.

O-ring

Viton	1	1
EPDM (Ethylene Propylene Rubber)	1	2
Kalrez 4079	1	3
HSN (Nitrile)	1	4
Buna-N	1	5
Neoprene	1	6
Chemraz	1	7
Polyurethane	1	8
Aegis PF128	2	1
Kalrez 2035	2	2
None ¹⁾	2	3

Probe Insertion Length

Add Order code Y01 and plain text:

"Insertion length ... cm"

Model option 1, 2 and Material of Construction option A: 60 ... 100 cm (23.6 ... 39.4 inch)

AA

Model option 1, 2 and Material of Construction option A: 101 ... 200 cm (39.8 ... 78.7 inch)

AB

Model option 1, 2 and Material of Construction option A: 201 ... 300 cm (79.1 ... 118.1 inch)

AC

Model option 1, 2 and Material of Construction option A: 301 ... 400 cm (118.5 ... 157.5 inch)

AD

Model option 1, 2 and Material of Construction option A: 401 ... 500 cm (157.9 ... 196.9 inch)

AE

Model option 1, 2 and Material of Construction option A: 501 ... 610 cm (197.2 ... 240.2 inch)

AF

Add Order code Y01 and plain text:

"Insertion length ... cm"

Model option 1 and Material of Construction option D: 60 ... 100 cm (23.6 ... 39.4 inch)

BA

Model option 1 and Material of Construction option D: 101 ... 200 cm (39.8 ... 78.7 inch)

BB

Model option 1 and Material of Construction option D: 201 ... 300 cm (79.1 ... 118.1 inch)

BC

Model option 1 and Material of Construction option D: 301 ... 400 cm (118.5 ... 157.5 inch)

BD

Model option 1 and Material of Construction option D: 401 ... 500 cm (157.9 ... 196.9 inch)

BE

Model option 1 and Material of Construction option D: 501 ... 610 cm (197.2 ... 240.2 inch)

BF

Add Order code Y01 and plain text:

"Insertion length ... cm"

Model option 1 and Material of Construction option F: 60 ... 100 cm (23.6 ... 39.4 inch)

CA

Model option 1 and Material of Construction option F: 101 ... 200 cm (39.8 ... 78.7 inch)

CB

Model option 1 and Material of Construction option F: 201 ... 300 cm (79.1 ... 118.1 inch)

CC

Model option 1 and Material of Construction option F: 301 ... 400 cm (118.5 ... 157.5 inch)

CD

Model option 1 and Material of Construction option F: 401 ... 500 cm (157.9 ... 196.9 inch)

CE

Model option 1 and Material of Construction option F: 501 ... 610 cm (197.2 ... 240.2 inch)

CF

Add Order code Y01 and plain text:

"Insertion length ... cm"

Model option 1 and Material of Construction option E: 60 ... 100 cm (23.6 ... 39.4 inch)

DA

Model option 1 and Material of Construction option E: 101 ... 200 cm (39.8 ... 78.7 inch)

DB

Model option 1 and Material of Construction option E: 201 ... 300 cm (79.1 ... 118.1 inch)

DC

Selection and Ordering data

Article No.

SITRANS LG200 Single Rod Rigid Probes

7ML1303-

SITRANS LG200 single rod rigid probes are used in applications where coating and buildup are likely. Used in applications with dielectric constant ≥ 10 , or $dk > 1.9$ when installed within 2 ... 6 inch of a metal tank wall or in cage or bridle.

Model option 1 and Material of Construction option E: 301 ... 400 cm (118.5 ... 157.5 inch)

DD

Model option 1 and Material of Construction option E: 401 ... 500 cm (157.9 ... 196.9 inch)

DE

Model option 1 and Material of Construction option E: 501 ... 610 cm (197.2 ... 240.2 inch)

DF

Add Order code Y01 and plain text:

"Insertion length ... cm"

Model option 1 and Material of Construction option J: 60 ... 100 cm (23.6 ... 39.4 inch)

EA

Model option 1 and Material of Construction option J: 101 ... 200 cm (39.8 ... 78.7 inch)

EB

Model option 1 and Material of Construction option J: 201 ... 300 cm (79.1 ... 118.1 inch)

EC

Model option 1 and Material of Construction option J: 301 ... 400 cm (118.5 ... 157.5 inch)

ED

Model option 1 and Material of Construction option J: 401 ... 500 cm (157.9 ... 196.9 inch)

EE

Model option 1 and Material of Construction option J: 501 ... 610 cm (197.2 ... 240.2 inch)

EF

Add Order code Y01 and plain text:

"Insertion length ... cm"

(³/₄" process connection only)

Model option 1 and Material of Construction option D and F: 60 ... 100 cm (23.6 ... 39.4 inch)¹³⁾

FA

Model option 1 and Material of Construction option D and F: 101 ... 180 cm (39.8 ... 72 inch)¹³⁾

FB

- 1) Model option 1 with Material of construction options D, E, F, available with O-ring option 23 only
- 2) Available with O-ring option 21 only
- 3) Available with Material of construction option A only
- 4) Available with Process connection options A1, A6, A7, B0, B3, C3 only
- 5) Available with Process connection options H1, H2, J1, J2, K1, K2, L1, L2, L3, L4, L5, L6 only.
- 6) Available with Process connection options E0, E1, E2, E3, F1, G1 only
- 7) Available with Material of construction option D only
- 8) Available with Material of construction options A and J only
- 9) Available with Probe Insertion Length options FA and FB only
- 10) Available with Material of construction option F only
- 11) Available with Material of construction option E only
- 12) Available with Model option 2 only
- 13) Available with Process connection options A7 and E0 only (³/₄"

Level Measurement

Continuous level measurement – Guided wave radar transmitters

SITRANS LG200

Selection and Ordering data	Order code
Further designs	
Please add "-Z" to Article No. and specify Order code(s).	
Enter the total insertion length in plain text description, max. 610 cm (240.2 inch)	Y01
Stainless steel tag. Measuring-point number/ identification (max. 27 characters); specify in plain text	Y15
Inspection Certificate Type 3.1 per EN 10204	C12
Manufacturer's test report (Hydrostatic Test)	C18
NACE MR-0175 materials traceability	D07
Operating Instructions	
English	Article No. 7ML1998-5KA02
French	7ML1998-5KA11
German	7ML1998-5KA32
Multi-language Quick Start manual This device is shipped with the Siemens Milltronics manual DVD containing the ATEX Quick Start and Operating Instructions library.	7ML1998-5XG81
Accessories	
TFE bottom spacer/endplate	7ML1930-1DJ
SITRANS RD100 Remote display - see Chapter 7	
SITRANS RD200 Remote display - see Chapter 7	
SITRANS RD500 web, datalogging, alarming, ethernet, and modem support for instrumentation - see Chapter 7	7ML5750-1AA00-0

Level Measurement

Continuous level measurement – Guided wave radar transmitters

SITRANS LG200

Selection and Ordering data

Article No.

SITRANS LG200 Single Rod Flexible Probes

7ML1304-

SITRANS LG200 single rod flexible probes are used in applications where coating and buildup are possible. Used in applications with dielectric constant ≥ 10 or $dk > 1.9$ when installed within 2 ... 6" of a metal tank wall or in cage or bridle. For solids version only, $dk > 4$.

Note:

In addition to the probe, please select a transmitter configuration to complete the SITRANS LG200 (ordered separately).

For orders of 10 or more, please consult factory.

Model

Single rod flexible probe 1
Single rod bulk solids flexible probe¹⁾ 2

Material of Construction

316/316L (1.4401/1.4404) stainless steel probe and process connection A

Process Connection (size/type)

316/316L (1.4401/1.4404)

2" NPT [(Taper), ANSI/ASME B1.20.1] A 0

G 2" [(BSPP), EN ISO 228-1] A 1

2" 150 lb ASME raised face flange A 2

2" 300 lb ASME raised face flange A 3

3" 150 lb ASME raised face flange B 1

3" 300 lb ASME raised face flange B 2

4" 150 lb ASME raised face flange C 1

4" 300 lb ASME raised face flange C 2

DN 50 PN 16 EN 1092-1 Type A flat faced flange D 1

DN 50 PN 25/40 EN 1092-1 Type A flat faced flange D 2

DN 80 PN 16 EN 1092-1 Type A flat faced flange E 1

DN 80 PN 25/40 EN 1092-1 Type A flat faced flange E 2

DN 100 PN 16 EN 1092-1 Type A flat faced flange F 1

DN 100 PN 25/40 EN 1092-1 Type A flat faced flange F 2

O-ring

Viton 1 1

EPDM (Ethylene Propylene Rubber) 1 2

Kalrez 4079 1 3

HSN (Nitrile) 1 4

Buna-N 1 5

Neoprene 1 6

Chemraz 1 7

Polyurethane 1 8

Aegis PF128 2 1

Kalrez 2035 2 2

Selection and Ordering data

Article No.

SITRANS LG200 Single Rod Flexible Probes

7ML1304-

SITRANS LG200 single rod flexible probes are used in applications where coating and buildup are possible. Used in applications with dielectric constant ≥ 10 or $dk > 1.9$ when installed within 2 ... 6" of a metal tank wall or in cage or bridle. For solids version only, $dk > 4$.

Flexible Rod Length

(To be shortened by customer as required)

1 m (39.4 inch) AA

2 m (78.7 inch) AB

3 m (118.1 inch) AC

4 m (157.5 inch) AD

5 m (196.9 inch) AE

6 m (236.2 inch) AF

7 m (275.6 inch) AG

8 m (315.0 inch) AH

9 m (354.3 inch) AJ

10 m (393.7 inch) AK

11 m (433.1 inch) AL

12 m (472.4 inch) AM

13 m (511.8 inch) AN

14 m (551.2 inch) AP

15 m (590.6 inch) AQ

16 m (629.9 inch) AR

17 m (669.3 inch) AS

18 m (708.7 inch) AT

19 m (748.0 inch) AU

20 m (787.4 inch) AV

21 m (826.8 inch) AW

22.5 m (885.8 inch) AX

¹⁾ Available with O-ring option 1 1 only (others on request)

Selection and Ordering data

Order code

Further designs

Please add "-Z" to Article No. and specify Order code(s).

Stainless steel tag. Measuring-point number/ identification (max. 27 characters); specify in plain text Y15

Operating Instructions

English Article No. 7ML1998-5KA02

French Article No. 7ML1998-5KA11

German Article No. 7ML1998-5KA32

Multi-language Quick Start manual Article No. 7ML1998-5XG81

This device is shipped with the Siemens Milltronics manual DVD containing the ATEX Quick Start and Operating Instructions library.

Accessories

SITRANS RD100 Remote display - see Chapter 7

SITRANS RD200 Remote display - see Chapter 7

SITRANS RD500 web, datalogging, alarming, ethernet, and modem support for instrumentation - see Chapter 7 7ML5750-1AA00-0

Level Measurement

Continuous level measurement – Guided wave radar transmitters

SITRANS LG200

Characteristic curves

4

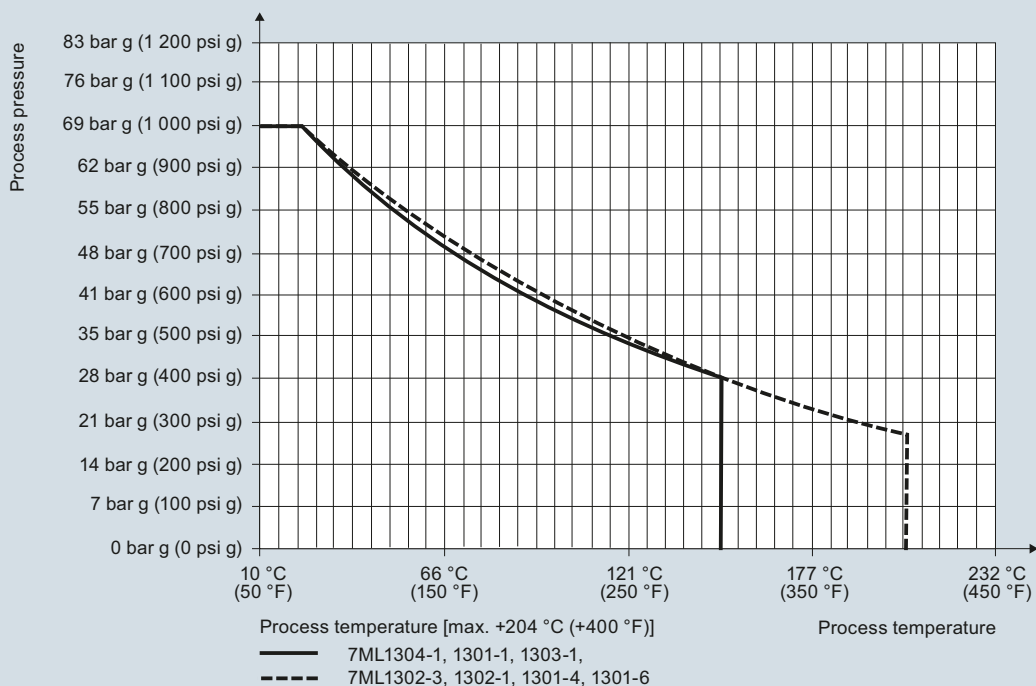
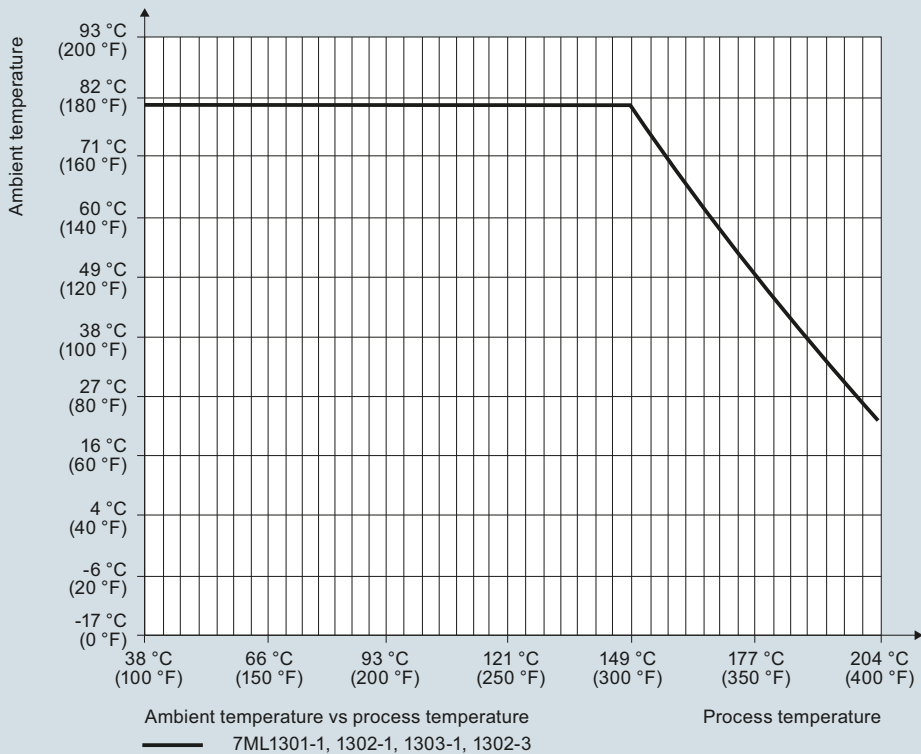

SITRANS LG200 Process Pressure/Temperature derating curves

Level Measurement

Continuous level measurement – Guided wave radar transmitters

SITRANS LG200

Dimensional drawings

SITRANS LG200 enclosure 7ML1300

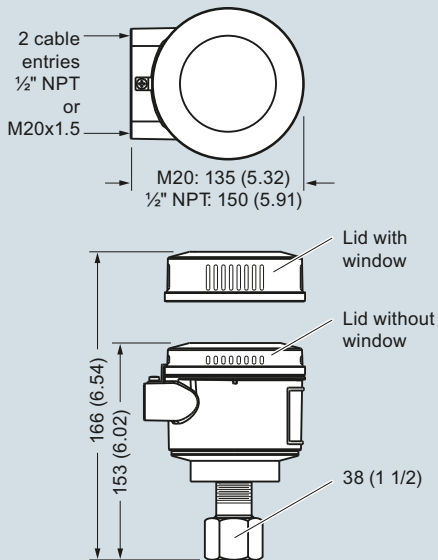

7ML1301-1 (7xA-x) probe, threaded and flanged connection

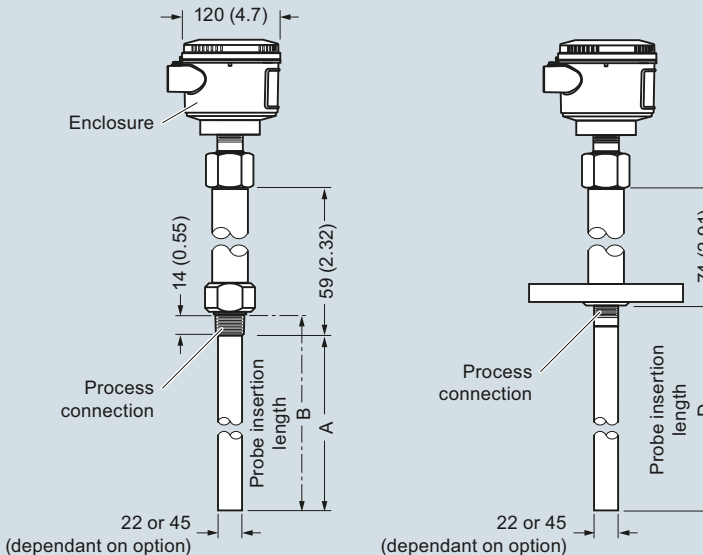

7ML1303-1 (7xF-x) probe, threaded and flanged connection
[7ML1303-2 HT Probe (7xJ-x)]

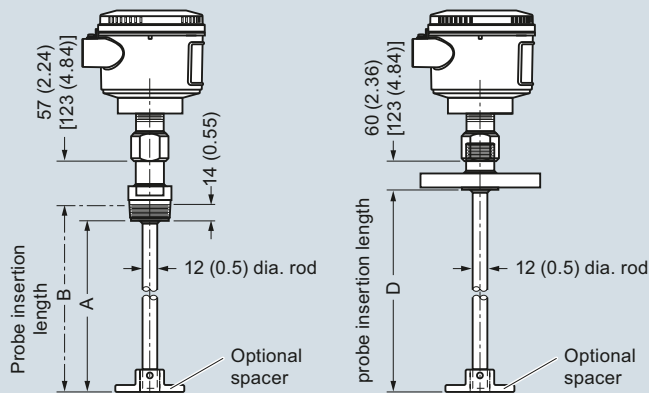

7ML1303-1D (7xF-E) probe, sanitary connection

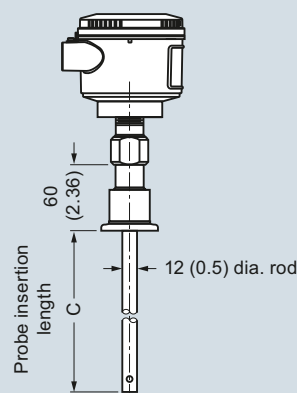

Probe connections and insertion lengths (Note: BSP connections differ from NPT)

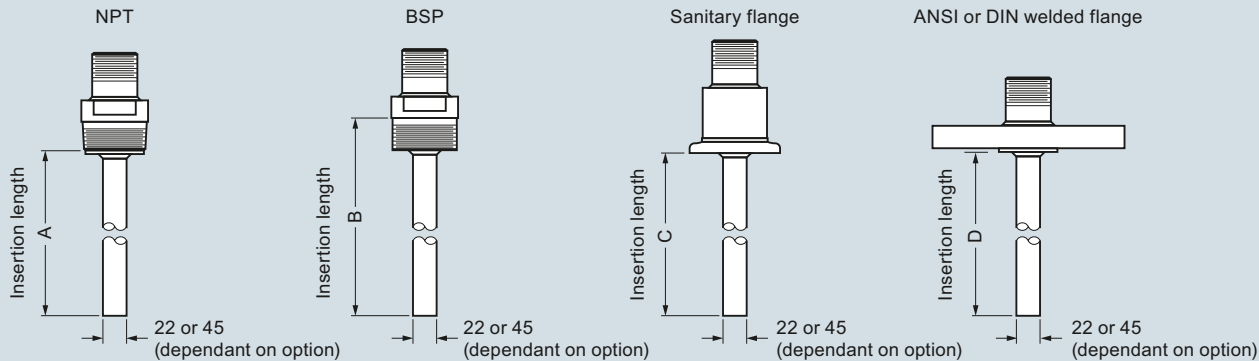

SITRANS LG200 (threaded process connection dimensions shown are NPT connections unless stated otherwise), dimensions in mm (inch)

Level Measurement

Continuous level measurement – Guided wave radar transmitters

SITRANS LG200

SITRANS LG200
7ML1304-1 (7x1-x) flexible probe,
Threaded or flanged connection

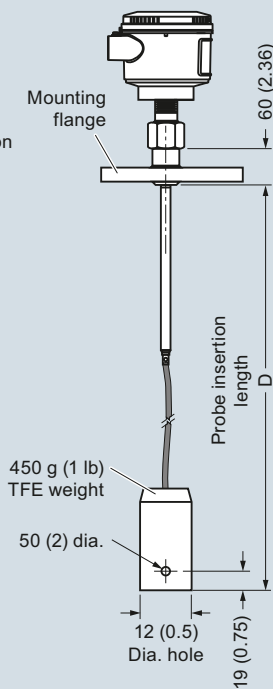
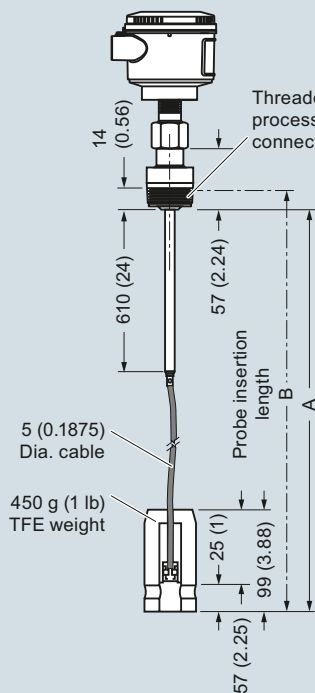

7ML1302-3 (7x7-x) twin rod flexible probe,
Threaded or flanged connection

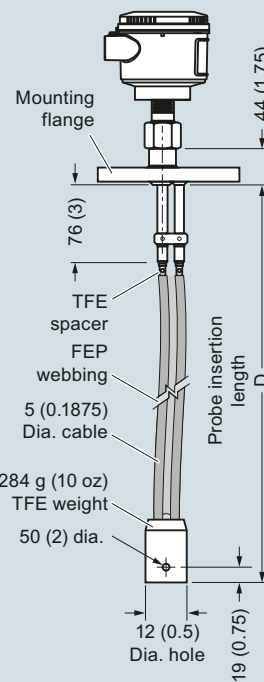
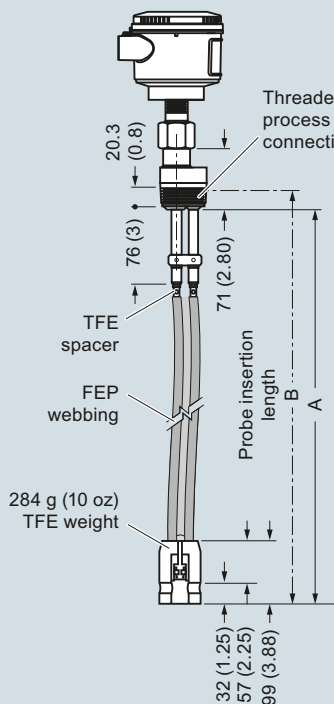

7ML1303-1E (7xF - F) probe,
Flat-faced flanged connection

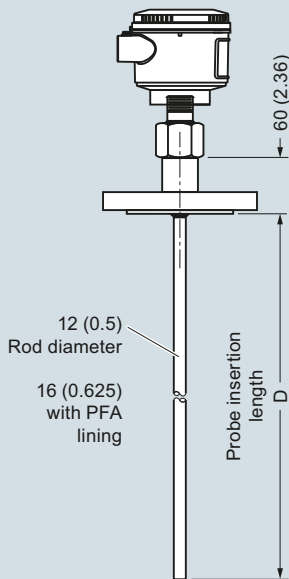

7ML1304-2 (7x2-x) bulk solids flexible probe,
Threaded or flanged connection

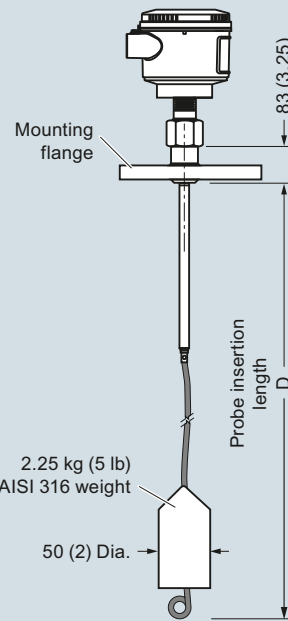
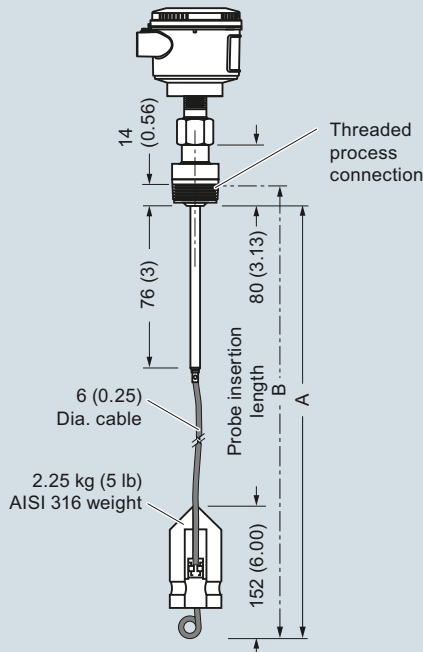

SITRANS LG200 (threaded process connection dimensions shown are NPT connections unless stated otherwise), dimensions in mm (inch)

4

Level Measurement

Continuous level measurement – Guided wave radar transmitters

SITRANS LG200

SITRANS LG200
7ML1302-1 (7xB-x) twin rod probe,
threaded and flanged connection

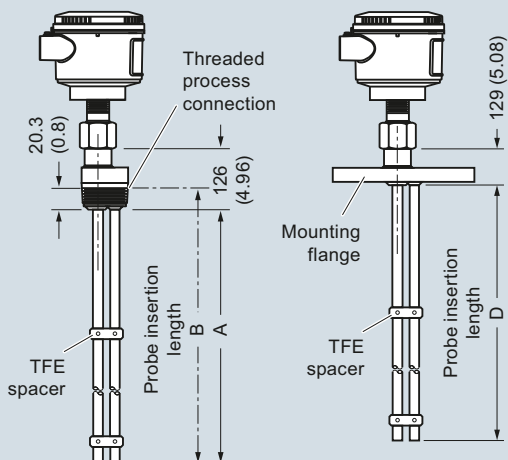

Twin rod end view

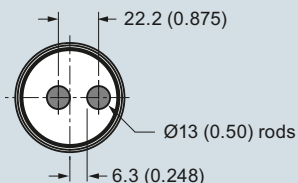

7ML1302-2 (7x5-x) twin rod bulk solids flexible probe
threaded or flanged connection

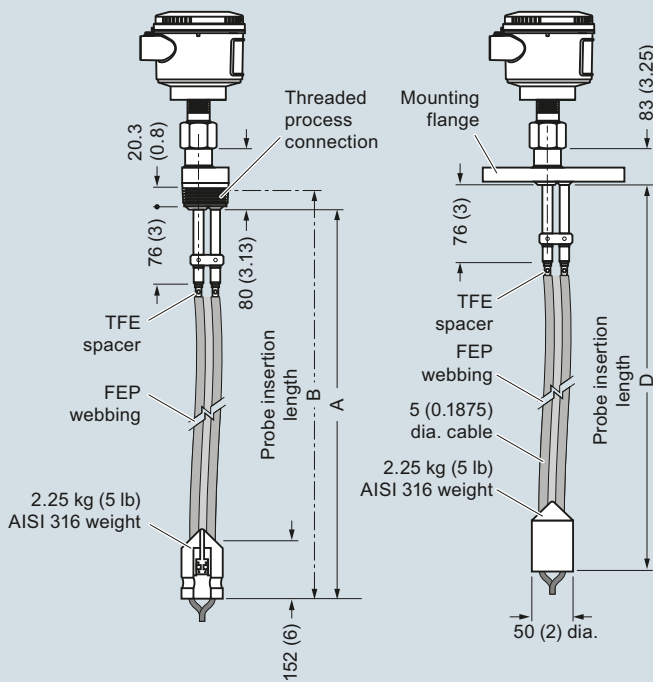

7ML1301-2 (7xD-x), 7ML1301-3 (7xP-x), 7ML1301-4 (7xR-x), 7ML1301-6 (7xT-x), threaded or flanged connection

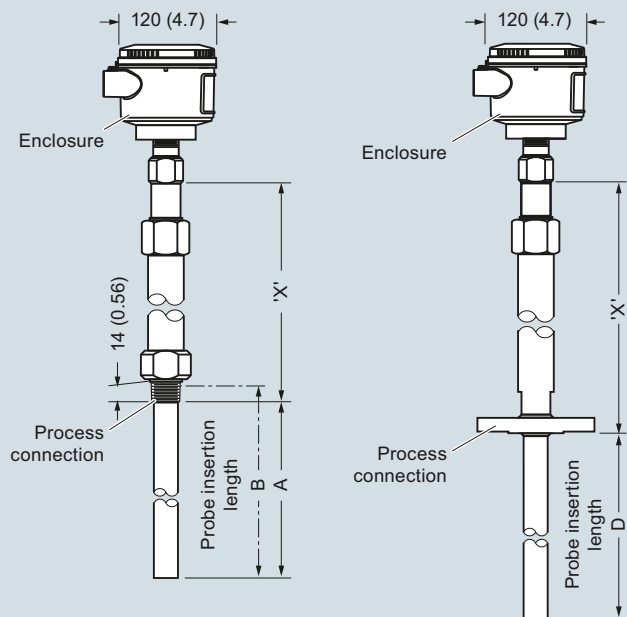

Probes	'X' Dimension (NPT)	'X' Dimension (flanged)
7ML1301-2 (coaxial HT/HP probe)	217 (8.55)	277 (10.91)
7ML1301-3 (coaxial HP probe)	106 (4.18)	166 (6.54)
7ML1301-4 (coaxial overflow/flooded cage probe), 7ML1301-6 (coaxial interface probe)	150 (5.89)	167 (6.57)
7ML1301-5 (coaxial HT/HP steam probe)	180 (7.10)	242 (9.52)

SITRANS LG200 (threaded process connection dimensions shown are NPT connections unless stated otherwise), dimensions in mm (inch)

Level Measurement

Continuous level measurement – Guided wave radar transmitters

SITRANS LG200

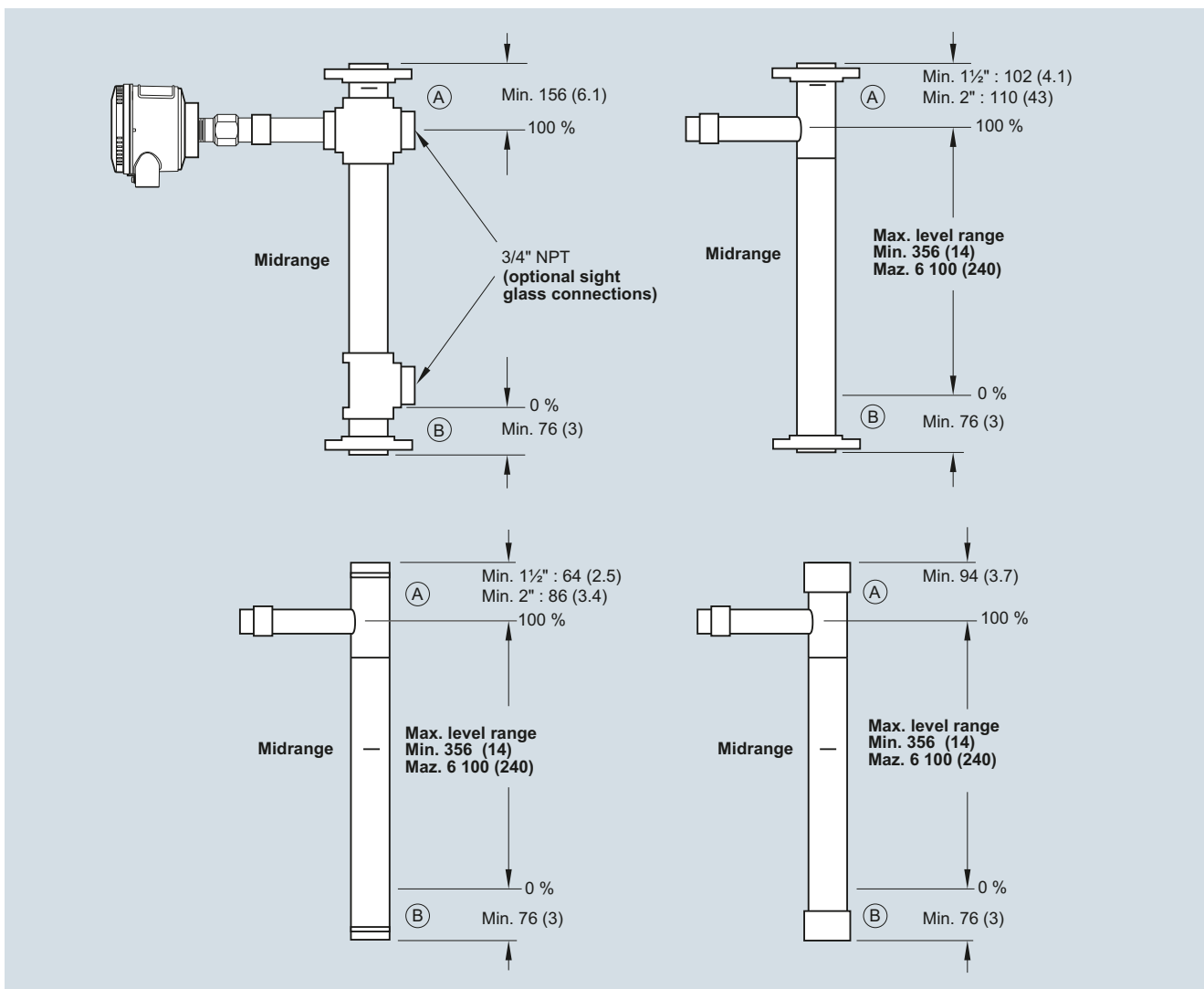

SITRANS LG200 - Model 7ML1305-1 Chamber Replacement Probe, dimensions in mm (inch)

4

Level Measurement

Continuous level measurement – Guided wave radar transmitters

SITRANS LG200

Schematics

SITRANS LG200 general purpose wiring

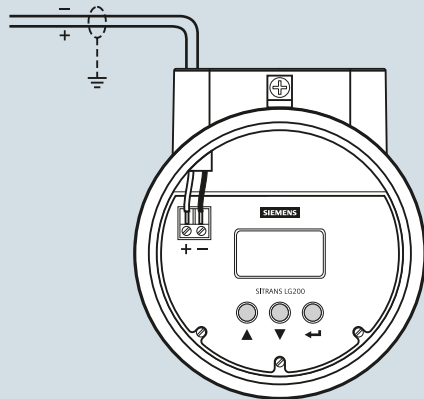

Intrinsically safe wiring

When connecting SITRANS LG200 in Intrinsically safe applications, install an approved IS barrier in the non-hazardous (safe) area.

Explosion proof wiring

When connecting SITRANS LG200 in hazardous areas with explosion hazard, the wiring for the transmitter must be contained in explosion proof conduit extending into the safe area. An explosion proof conduit fitting is not required within 457 mm (18 inch) of the transmitter. An explosion proof conduit fitting is required between the hazardous and safe areas.

SITRANS LG200 connections